



Rockhampton Regional Council

Registered Service Provider No. SP493

Drinking Water Quality Management Plan

October 2014

Version Control

Revision No.	Revision Description	Revision Date	Reviewer
0	Original Approved Version	June 2012	Jason Plumb, Nimish Chand
1	First Annual Review	October 2014	Ariane Leyden, Jason Plumb, Nimish Chand

TABLE OF CONTENTS

EXECUTIVE SUMMARY.....	5
1 REGISTERED SERVICE DETAILS.....	6
1.1 Service Provider Name.....	6
1.2 Drinking Water Service Operator.....	6
1.3 Drinking Water Schemes Covered By This Plan.....	6
1.4 Current Details for Location, Size and Demand of Drinking Water Schemes.....	6
2 DETAILS OF DRINKING WATER SCHEME INFRASTRUCTURE.....	8
2.1 Overview of Scheme Infrastructure.....	8
2.2 Water Sources for Drinking Water Supply.....	14
2.2.1 Fitzroy River Barrage Storage.....	14
2.2.2 No.7 Dam and Fletcher Creek Weir.....	15
2.3 Water Treatment Processes.....	16
2.3.1 Glenmore Water Treatment Plant.....	16
2.3.2 Mount Morgan Water Treatment Plant.....	19
2.4 Availability of Equipment and Critical Spares.....	21
2.5 Water Distribution and Reticulation Infrastructure.....	22
2.5.1 Overview of Operation – Rockhampton Water Supply Scheme.....	22
2.5.2 Overview of Operation – Capricorn Coast Water Supply Scheme.....	23
2.5.3 Overview of Operation – Mount Morgan Water Supply Scheme.....	24
2.5.4 Known Areas of Low Pressure within Distribution Systems.....	30
2.5.5 Known Areas of Long Detention Time within Distribution Systems.....	30
2.6 Stakeholders Involved in Managing Drinking Water Infrastructure.....	31
3 CATCHMENT AND WATER QUALITY INFORMATION.....	32
3.1 Catchment Characteristics.....	32
3.1.1 Fitzroy River Basin.....	32
3.1.2 Dee River and Fletcher Creek.....	33
3.2 Raw Water and Drinking Water Quality.....	34
3.2.1 Rockhampton Water Supply Scheme.....	34
3.2.2 Mount Morgan Water Supply Scheme.....	37
3.3 Drinking Water Quality Incidents.....	39
3.4 Drinking Water Quality Complaints.....	40
4 HAZARD IDENTIFICATION.....	41
5 ASSESSMENT OF RISKS.....	43
6 MANAGING RISKS.....	61
6.1 Unacceptable Risks to Drinking Water Quality.....	61
7 OPERATION AND MAINTENANCE PROCEDURES.....	62
7.1 Manuals and Procedures for Drinking Water Schemes.....	62
7.2 Preventative Maintenance Program.....	63
7.3 Reactive Maintenance Management.....	64
8 MANAGEMENT OF EMERGENCIES, INCIDENTS, OR EXCURSIONS FROM NORMAL PERFORMANCE.....	64
8.1 Emergency Response Plan.....	64
8.2 Managing Drinking Water Incidents or Excursions from Normal Operational Performance.....	64
8.3 Emergency Contact Information.....	67
9 SERVICE WIDE SUPPORT – INFORMATION MANAGEMENT.....	69
9.1 Information Management Systems.....	69

9.2	Reporting Activities	69
10	OPERATIONAL AND VERIFICATION MONITORING PROGRAMS	70
10.1	Operational Monitoring Within Drinking Water Scheme	70
10.2	Verification Monitoring within Drinking Water Schemes	71
11	BEST PRACTICE INITIATIVES	75
11.1	Commitment to Drinking Water Quality Management	75
11.2	Research and Development Activities	76
11.3	Staff Awareness and Training.....	76
12	RISK MANAGEMENT IMPROVEMENT PROGRAM	77
APPENDIX A.....	APPENDIX A.....	79
APPENDIX B.....	APPENDIX B.....	80
APPENDIX C.....	APPENDIX C.....	83

EXECUTIVE SUMMARY

In accordance with section 94 of the *Water Supply (Safety and Reliability) Act*, the purpose of the Drinking Water Quality Management Plan (DWQMP) is to protect public health through the comprehensive management of drinking water quality. The drinking water quality management provisions in Queensland follow a risk-based management approach and it is intended that this approach is documented in a plan that demonstrates effective management of drinking water services to ensure a safe and reliable supply of drinking water is provided.

The DWQMP is intended to be a living document that reflects the requirements of the water service provider and what needs to be actioned on a day to day basis now and into the future to ensure the supply of safe drinking water. In doing so, the DWQMP will then be used by the water service provider as a means of achieving drinking water quality outcomes in the short and long term through the demonstration that good drinking water quality management measures are in place. A thorough understanding, and effective management of, the drinking water infrastructure, water treatment processes, hazards and hazardous events, and the monitoring of operational processes and the quality of drinking water supplied to customers is therefore essential. This DWQMP, therefore, documents the information required in order to achieve the delivery of safe and reliable drinking water services.

The DWQMP also requires the generation and implementation of a Risk Management Improvement Program (RMIP). The purpose of the RMIP is to describe the management measures proposed for any unacceptable residual risk. The description of these measures must include the proposed measures, actions, strategies or processes, priorities and implementation timeframes. The RMIP included in the DWQMP is based on the following elements:

- Element 1 - Infrastructure Upgrades and Improved Infrastructure Performance
- Element 2 - Optimisation of Information Management and Reporting Capabilities
- Element 3 - Enhanced Engagement with Stakeholders Associated with Drinking Water Infrastructure Management
- Element 4 - Improved Service Through Staff Awareness and Training
- Element 5 - Enhanced Water Quality Performance

These five elements represent high priority action items for which completion is required in order to mitigate risks posed to drinking water quality. The timeframe for completion and availability of funding for completion of each element is provided.

The recent de-amalgamation of the Livingstone Shire Council from the Rockhampton Regional Council is reflected in this revision of the DWQMP. Any content in the original DWQMP that does not specifically relate to the management of water quality either solely or jointly by Rockhampton Regional Council (Fitzroy River Water) have been removed from this document.

1 REGISTERED SERVICE DETAILS

1.1 Service Provider Name

Rockhampton Regional Council – Registered Number 493
Ph: 1300 22 55 77| Fax: 1300 22 55 79
Address: PO Box 1860, Rockhampton Q 4700 Web:
www.rockhamptonregion.qld.gov.au

1.2 Drinking Water Service Operator

Fitzroy River Water (a business unit of Rockhampton Regional Council)
Ph: 1300 22 55 77| Fax: 1300 22 55 79
Address: PO Box 1860, (Belmont Road), Rockhampton Q 4700 Web:
www.rockhamptonregion.qld.gov.au

1.3 Drinking Water Schemes Covered By This Plan

The following schemes are described or referred to in this DWQMP:

Rockhampton Water Supply Scheme (Rockhampton Regional Council)
Mount Morgan Water Supply Scheme (Rockhampton Regional Council)
Capricorn Coast Water Supply Scheme (Livingstone Shire Council).

For the purposes of the DWQMP, unless otherwise stated in the text, a scheme refers to the entire contiguous distribution system irrespective of the local government ownership of the various parts of the scheme.

1.4 Current Details for Location, Size and Demand of Drinking Water Schemes

Figure 1.1 provides an overview of the location of each of the drinking water schemes described in this DWQMP. Table 1.1 lists current information on the names of the communities, the population size, the number of connections and the average daily demand for each drinking water scheme. Table 1.2 provides an indication of the anticipated population, connections and demand for each of the schemes in the year 2021. The population projections for 2021 are based on calculations using the Planning Assumption Model (PAM) projections developed within Rockhampton Regional Council localities.

Figure 1.1: Map showing the location of the two drinking water schemes (Rockhampton, Mount Morgan) operated by Fitzroy River Water and the neighbouring Council areas.

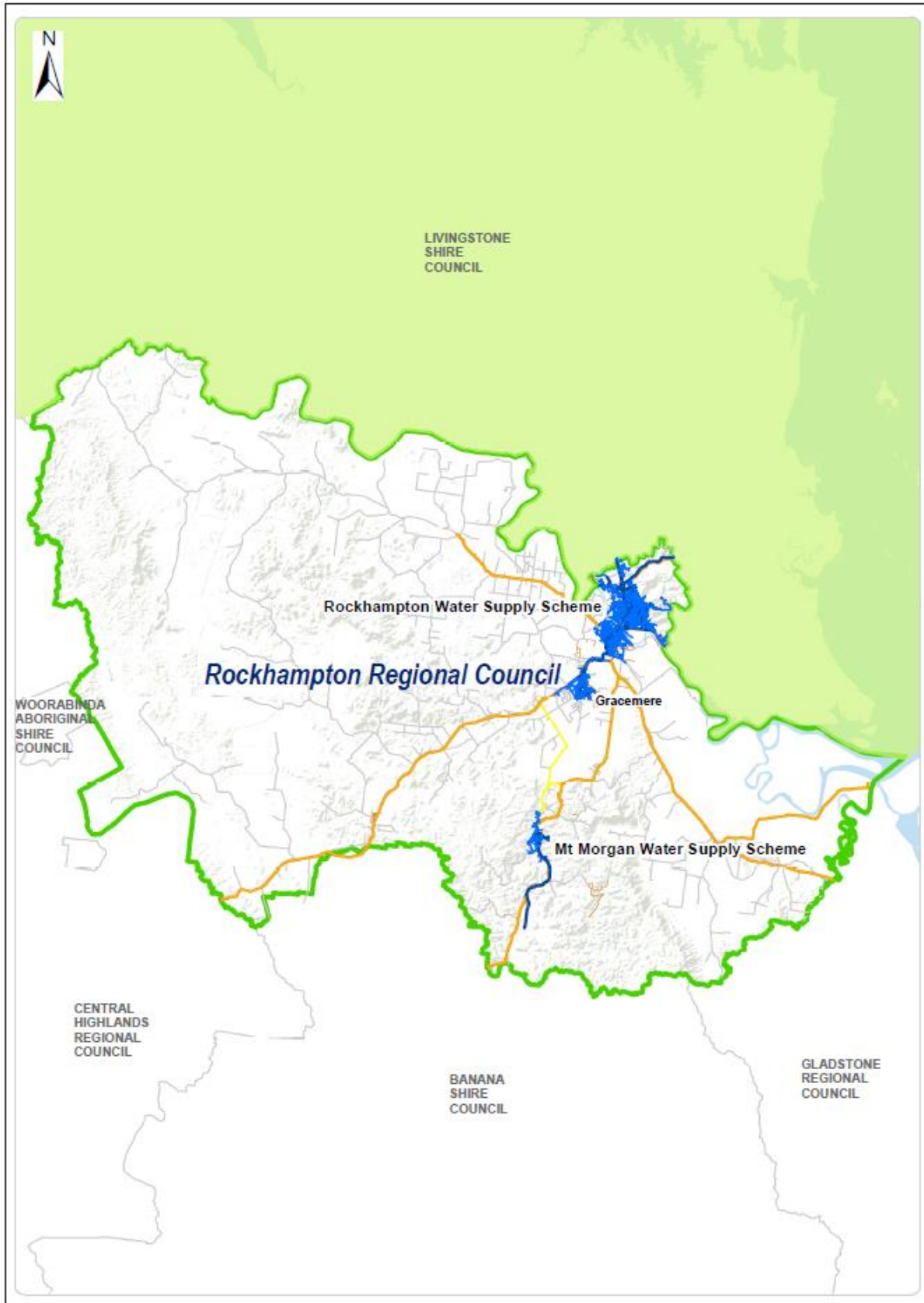

Table 1.1: Current information for the communities fully or partially served by the water infrastructure operated by Rockhampton Regional Council, population, number of connections and demand for each drinking water supply scheme

Scheme	Communities Served	Population ^a	Connections ^a	Average Demand (ML/d)
Rockhampton (localities part of Livingstone Shire Council)	Rockhampton, Gracemere, (Nerimbera, The Caves, Etna Creek, Glenlee, Glendale, Rockyview, Mt Charlton)	77,140	28,200	49
Capricorn Coast (localities part of Livingstone Shire Council)	(Yeppoon, The Causeway, Kinka Beach, Zilzie, Emu Park, Keppel Sands)	22,570	9,630	11
Mount Morgan	Mount Morgan, Baree	3,130	1,470	1.0

^aSource: SWIM Reporting 2013.

Table 1.2: Estimated population, number of connections and demand for each drinking water scheme in 2021.

Scheme	Population ^a	Connections	Average Demand (ML/d)
Rockhampton	92,853	31,150	53.0
Capricorn Coast	26,621	13,564	11.4
Mount Morgan	3,122	1,457	0.94

^aSource: PAM population projections for Rockhampton, Capricorn Coast and Mount Morgan 2014

2 DETAILS OF DRINKING WATER SCHEME INFRASTRUCTURE

2.1 Overview of Scheme Infrastructure

Tables 2.1 to 2.3 and Figures 2.1 to 2.3 provide summary information of the infrastructure and scheme layout for each drinking water scheme that is either fully or partially served by water infrastructure that is owned and operated by Rockhampton Regional Council (RRC). Only water source and treatment infrastructure that is owned and operated by RRC, or is involved in supplying drinking water to RRC customers is described in detail in this revised DWQMP. In Figure 2.1 due to the size of the scheme and the number of WPS in this scheme, only bulk transfer WPS or those that supply to whole supply zones are shown.

A water grid-style connection exists between the Rockhampton and Capricorn Coast Water Supply Schemes. Figures 1.1, 2.1 and 2.2 show the location of this connection point. Although the Capricorn Coast Water Supply Scheme is now owned and operated by the newly re-formed Livingstone Shire Council, its distribution system is shown and described briefly to indicate the manner in which it is served by the Rockhampton Water Supply Scheme. Similarly, the areas to the north and south of the existing Rockhampton Water Supply Scheme that are now again part of the

Livingstone Shire Council (e.g. north of Ramsay Creek WPS to Mt Charlton and the Nerimbera locality in South-East Rockhampton) are described due to their direct physical link to the Rockhampton Water Supply Scheme despite their ownership by Livingstone Shire Council.

Table 2.1: Summary of Infrastructure for the Rockhampton Water Supply Scheme

Rockhampton Water Supply Scheme		
Source	Fitzroy River 50,383 ML/annum	
Source Infrastructure	Fitzroy Barrage and associated pondage	
Treatment Plant	Glenmore Water Treatment Plant coagulation, flocculation, sedimentation, filtration, pH correction and disinfection Treatment Capacity = 120 ML/d	
Reservoirs	Number	19
	Capacity	122.3 ML
Pump Stations	32	
Length of Mains and Common Services	816.9 km	
No. of rechlorination sites	9	

Table 2.2: Summary of Infrastructure for the Capricorn Coast Water Supply Scheme

Capricorn Coast Water Supply Scheme		
Source	Waterpark Creek 5,000 ML/annum, Fitzroy River 50,383 ML/annum via the Rockhampton to Yeppoon Water Supply Pipeline.	
Source Infrastructure	Waterpark Creek Weir, Fitzroy Barrage, Kelly's Off-Stream Storage	
Treatment Plant	Glenmore Water Treatment Plant (see Table 3) Woodbury Water Treatment Plant Coagulation, flocculation, sedimentation, filtration, pH correction and disinfection Treatment Capacity = 21.6 ML/d	
Reservoirs	Number	11
	Capacity	33.7 ML
Pump Stations	15	
Length of Mains and Common Services	423 km	
No. of rechlorination sites	3	

Figure 2.1: Schematic of the Rockhampton Water Supply Scheme (Bulk WPS or WPS to whole supply zones shown only)

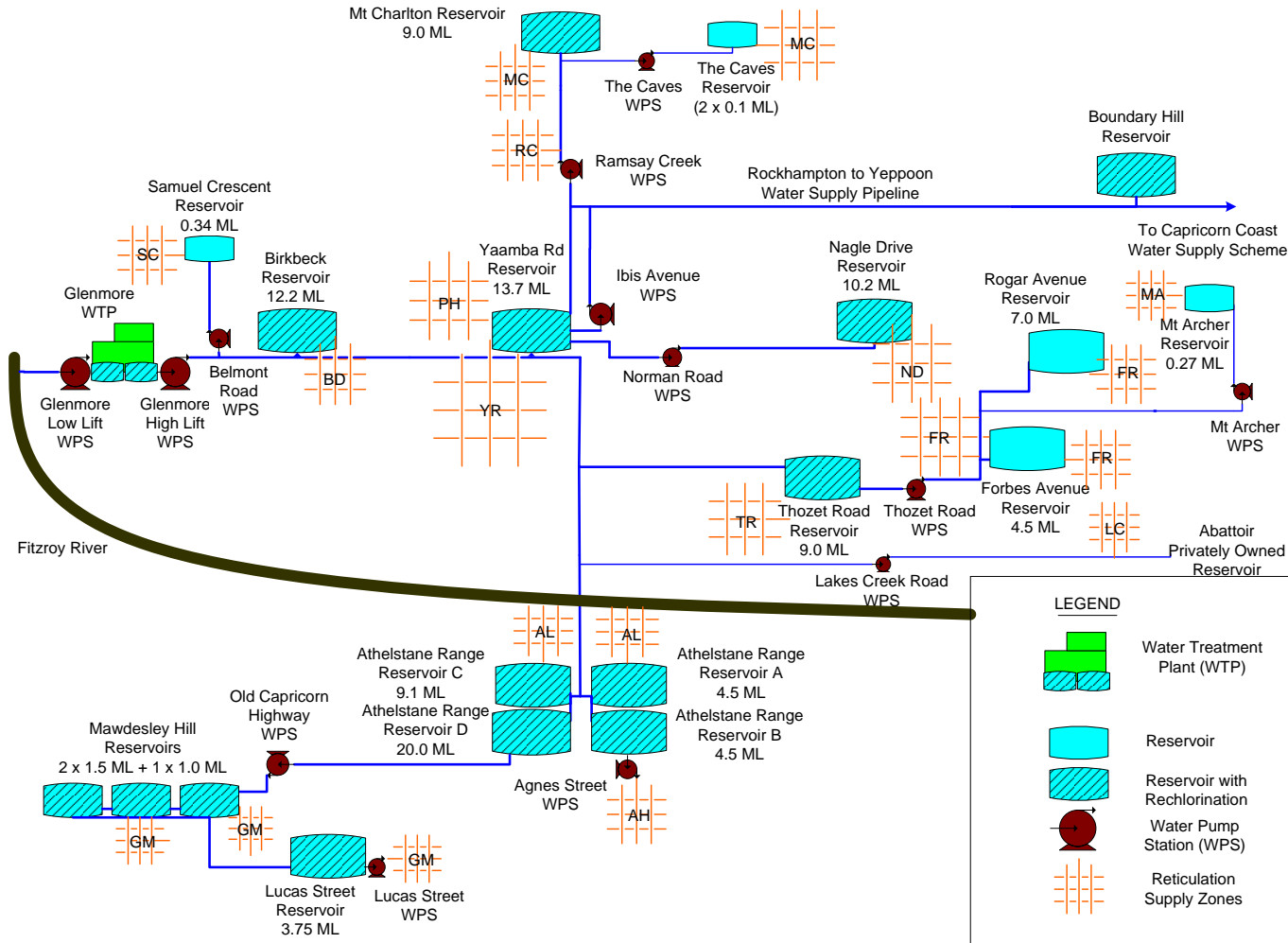

Figure 2.2: Schematic of the Capricorn Coast Water Supply Scheme (Livingstone Shire Council Owned and Operated)

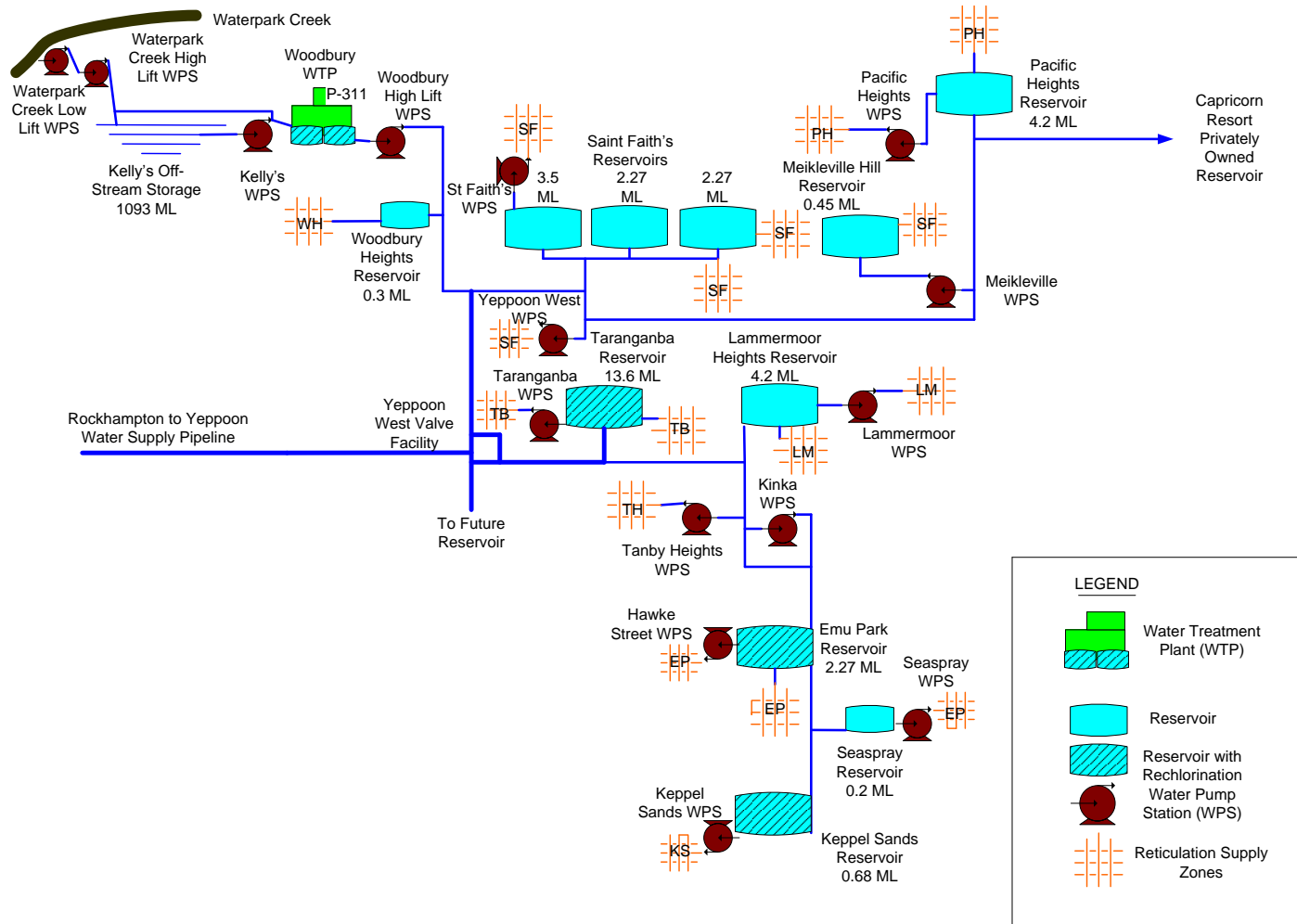
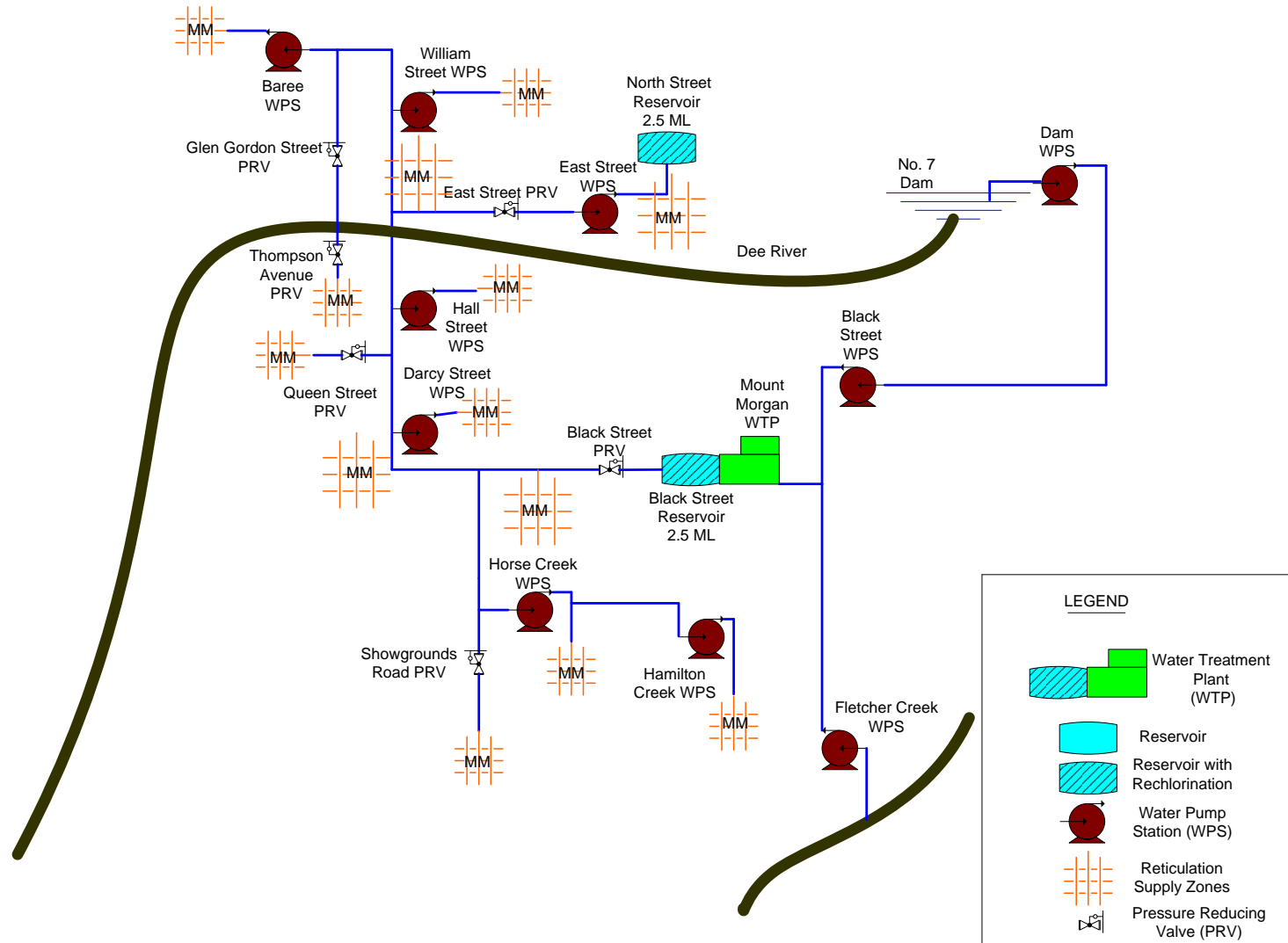

Table 2.3: Summary of Infrastructure for the Mount Morgan Water Supply Scheme

Mount Morgan Water Supply Scheme	
Source	Dee River – Allocation 584 ML/ annum Fletcher Creek Weir – Order in Council (06/02/1986) to take 700 ML/annum
Treatment Plant	Mount Morgan Water Treatment Plant coagulation, sedimentation, filtration, pH correction and disinfection Treatment Capacity = 2.6 ML/d
Reservoirs	No. 2 Capacity 5.0 ML
Pump Stations	10
Length of Mains and Common Services	66.4 km
No. of rechlorination sites	2

Figure 2.3: Schematic of the Mount Morgan Water Supply Scheme



2.2 Water Sources for Drinking Water Supply

2.2.1 Fitzroy River Barrage Storage

The Rockhampton and Capricorn Coast Water Supply Schemes are supplied with raw water drawn from RRC's 50,383 ML/year high priority water allocation, which is stored in an impoundment behind the Fitzroy Barrage.

The Barrage sits at the bottom of the Fitzroy River Catchment which is the second largest in Australia covering in excess of 140,000 km². Due to the size of the catchment and the predominantly sub-tropical climate, the system is subject to highly variable but historically reliable flows with an average discharge between 5,000,000 and 6,000,000 ML/year. Fitzroy River Water (FRW) operates the Barrage in accordance with a Resource Operations Plan (ROP) which defines the requirement for storage management, environmental passing flows and water quality as well as other monitoring that is required to be performed. Releases from the Barrage impoundment are made by controlling the operation of 18 vertical lift gates that separate the freshwater from the downstream estuary using a fully automated control system.

FRW manages the storage of 11,583 ML/year of medium priority/high priority water for 189 licensed water allocation holders who draw water from the Barrage impoundment. These allocations are diverted by private infrastructure but FRW, as the delegate of the registered water service provider, oversees the process and ensures the objectives of the *Water Act 2000* are met as they affect the service provider.

The operating rules for the Barrage storage are entwined with the Eden Bann storage which stores a 24,000 ML/year high priority water allocation for the Stanwell Corporation. The Stanwell Corporation draws its water from the Barrage impoundment but water is released from the Eden Bann storage into the Barrage for this purpose.

The Barrage impoundment and upstream catchment are unprotected surface waters that are impacted by a multitude of different land use practices and industrial activities that occur in the various sub-catchments within the Fitzroy Basin. As such the raw water in the Barrage storage is subject to the potential impacts that occur within the catchment. Typical water quality issues that arise include cyanobacterial blooms, mine water discharges that alter water quality aesthetics and high flow or flooding events that lead to highly variable raw water quality e.g. rapid changes in turbidity, fluctuations in Fe and Mn concentration. The raw water contains a low concentration of fluoride at ~0.1 mg/L. A thorough review of the Fitzroy Basin, its characteristics, status and management framework is provided in the Fitzroy Basin Water Quality Improvement Report (2008) prepared by the Fitzroy Basin Association Incorporated.

The Glenmore Water Treatment Plant intake structure is located approximately 5 km upstream of the Fitzroy Barrage. The intake is designed to provide four different depths from which water is pumped for treatment, from the surface to more than 5 m deep. Multiple high level intake structures provide the ability to pump raw water for treatment during high flow and flooding events. All intake structures are designed to withstand damage from debris and high flows that occur during flooding events.

The Glenmore Low Lift Water Pump Station (WPS) contains four centrifugal pumps ranging in capacity from 270 L/sec to 715 L/sec. This WPS pumps raw water from the river intake into the inlet of the Glenmore WTP which is located about 250 m away from the riverbank. Combinations of these four pumps can be operated to meet the demand requirements and to balance the flow rate of raw water into the Glenmore WTP with the flow rate of drinking water out of the clear water storage reservoirs.

2.2.2 No.7 Dam and Fletcher Creek Weir

The Mount Morgan Water Supply Scheme obtains its water from the No.7 Dam (primary water source) and the Fletcher Creek Weir (alternate source). Currently 100% of the Mount Morgan Water Supply is sourced from the No.7 Dam with the Fletcher Creek source available for use only in the event that water from the No.7 Dam is either unfit for use or unavailable. The No.7 Dam is located on the Dee River which runs through the centre of Mount Morgan. The No.7 Dam was originally constructed in 1900 by the Mount Morgan Gold Mine Company and was later raised an additional 4.5 m in 1999. The total storage capacity of the dam is 2,800 ML.

The Fletcher Creek Weir was originally built in 1966 and was later upgraded to a three row steel piling weir in 1984. The total storage capacity of the Fletcher Creek Weir is approximately 340 ML. Modelling of water storage levels based on current demand suggests that by the time the No.7 Dam level drops to the point where water is unavailable for use, the Fletcher Creek Weir will already be empty and therefore useless as a water source.

For many years long term water security in Mount Morgan has been an area of much attention. The area receives lower annual rainfall than the coastal parts of the region and the Dee River and Fletcher Creek catchments are quite small by comparison. Based on historical data, the 99.9% reliable supply from the No.7 Dam is 1.6 ML/d. Therefore based on current and future demand, the available water supply may be sufficient in 99.9 out of 100 months until at least 2020.

Land use in the Dee River and Fletcher Creek catchments above the two storages is predominantly cattle grazing or undisturbed bushland, with each catchment an unprotected catchment. The two storages are upstream from the extensive gold and copper mining activities associated with Mount Morgan's history. Water quality issues associated with these two storages include problems associated cyanobacterial blooms and occasional increases in the concentrations of iron and manganese in the raw water.

The raw water intake at the No.7 Dam is located approximately 15 m away from dam wall and approximately 20 m from the shore of the dam. An anchored pontoon provides the support for the raw water intake pipe which is supplied via a single submersible pump capable of pumping 25 L/sec located at a fixed depth (600 mm) in water with a maximum depth of 12 m. An identical submersible pump is available for rapid installation as a replacement in the event of a raw water pump failure.

2.3 Water Treatment Processes

Water treatment for each of the drinking water schemes is performed using slight variations of the same conventional coagulation, flocculation, sedimentation, filtration, pH correction and disinfection process. The individual treatment processes are described below for each water treatment plant.

2.3.1 Glenmore Water Treatment Plant

The Glenmore WTP in Rockhampton is the source of treated water supplied to residents in Rockhampton, Gracemere, The Caves and also the Capricorn Coast via the Rockhampton to Yeppoon Water Supply Pipeline. Commencing operation in 1971, the Glenmore WTP has a maximum capacity to treat 120 ML/d and the maximum demand recorded on the system was 114 ML/d, which was recorded in 2002/03 prior to the introduction of water meters in Rockhampton. Since consumption-based charging commenced in 2005, maximum demand on the Glenmore WTP has been approximately 100 ML/d.

The design of the Glenmore WTP has been maximised to handle very high raw water turbidity and large rapid variations in raw water turbidity. There are no defined raw water turbidity operational limits for the operation of the WTP. The WTP has effectively treated raw water with turbidity in excess of 2000 NTU and is consistently capable of achieving more than 4-log removal of turbidity through its treatment stages. Operational performance is monitored using on-line and manual turbidity measurement to ensure the effectiveness of treatment barriers (see further descriptions below).

Figure 2.4 shows a schematic representation of the treatment processes used at the Glenmore WTP. Water flows through coarse mesh screens into the river inlet structure and gravitates to the low-lift pump station where it is pumped to the inlet of the WTP. Upon entry to the inlet of the WTP, the option exists for pre-chlorination to be used for the oxidation of metals such as iron and manganese, or to assist with the destruction and removal of cyanobacteria. In recent years no pre-chlorination has been conducted and the use of this pre-treatment step is unlikely unless a severe cyanobacterial bloom event occurs in the source water. The WTP inlet is designed to promote rapidly mixing conditions, and at this point the influent raw water is dosed with a coagulant (polyaluminium chlorhydrate, Pac 23, Orica) using a duty/standby two pump set system. The coagulant-dosed raw water is then pumped into two identical parallel train flocculation/sedimentation basins, each with a design capacity of 70 ML/d.

At the entry to the first bay of the flocculation tank powdered activated carbon (Acticarb PS1000, Activated Carbon Technologies) is dosed into the water using a duty/standby activated carbon dosing system when required to remove soluble organics. The flocculation tank is comprised of three bays that contain horizontal paddle mixers to provide gentle mixing to promote flocculation. The direction of flow through each bay is opposite to the previous bay. Upon entry to the second bay of each flocculation tank, the water is dosed with a polyacrylamide (NALCLEAR® 8170 PULV) as a water clarification aid.

Water containing well formed floc particles leaves the flocculation tank and enters the sedimentation tank through a series of slots in the wall of the final flocculation bay. At this point the absence of mixing promotes the settling of the floc particles as

the water passes through the sedimentation tank. The majority of the sedimentation process occurs within the first half of the sedimentation tank. A mechanical sludge scraper in each sedimentation tank is used to remove settled sludge through drains in the bottom of the sedimentation tank. Water treatment sludge is collected in on-site sludge holding lagoons. Gravity separation is used to separate the sludge from the supernatant which is then returned to the Barrage impoundment. Strict discharge conditions require that the supernatant is of high quality and therefore poses no risk to the quality of raw water in the Barrage storage. The second half of each sedimentation tank contains a tube settler array to maximise sedimentation of fine floc particles. At this point, clarified top water (target turbidity of 1.0 to 1.5 NTU measured by a pre-filtration on-line turbidity meter) is collected via finger weirs into collection channels which then transfer the clarified water to the filters.

Figure 2.4: Schematic Representation of the Treatment Process at the Glenmore WTP.

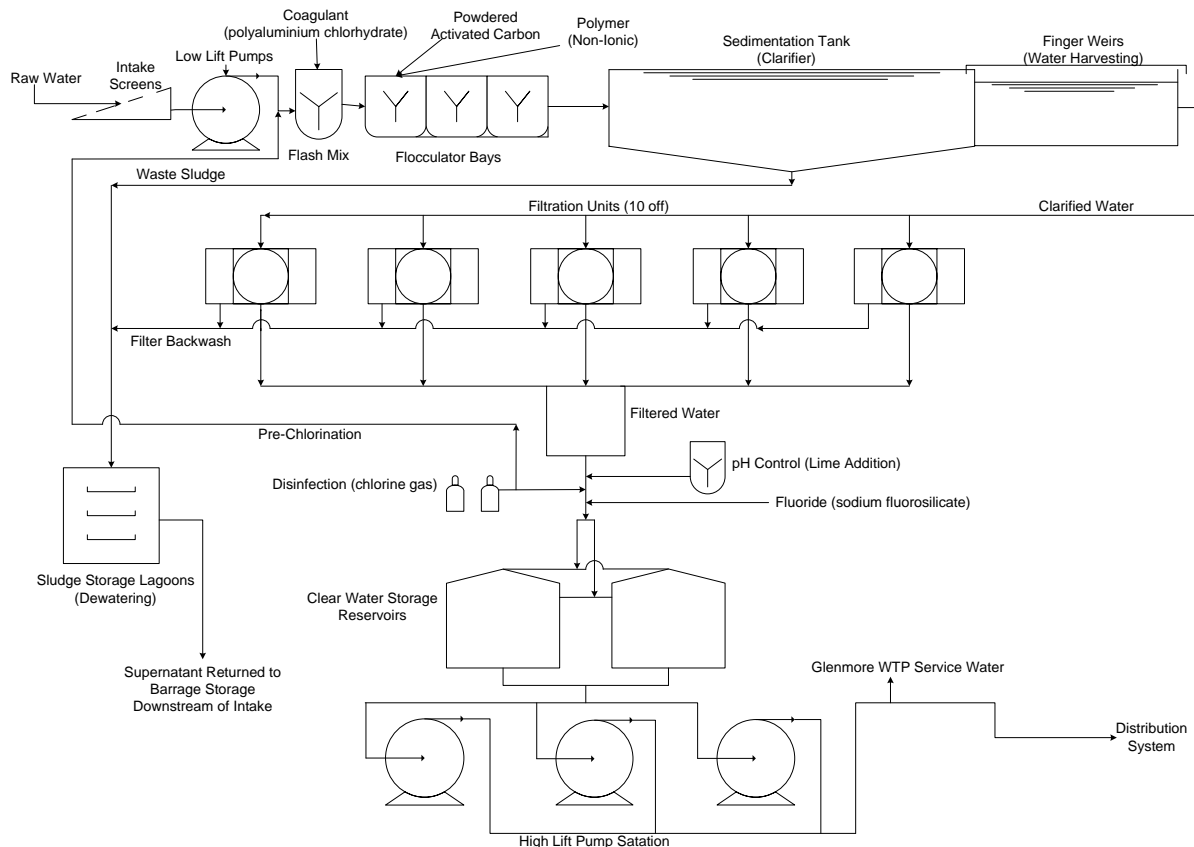

Filtration is achieved using 10 rapid gravity sand and garnet filters of 1100 mm total bed depth. Each filter contains three 100 mm deep layers of garnet gravel (effective size = 0.6-1.2 mm, 1.2-2.4 mm and 2.4-4.8 mm) beneath a 200 mm layer of fine garnet (effective size = 0.3-0.4 mm) which is beneath a 600 mm deep layer of top sand (effective size = 0.9-1.0 mm). Filters are automatically backwashed based on time, loss of head or turbidity triggers which are monitored in real-time by the Honeywell Programmable Logic Controller (PLC) and Experion PKS Supervisory Control and Data Acquisition (SCADA) system. Backwashing is achieved using a duty/standby two pump set and duty/standby blowers to air scour and wash each

filter. Each filter contains a filter-to-waste function which enables poor quality filtered water to be wasted until the target water quality is achieved. Filters typically produce water with turbidity of <0.1 NTU, with 0.3 NTU used as a setpoint to trigger a backwash (as per the USEPA Long Term 2 Enhanced Surface Water Treatment Rule). Filter backwash or other waste waters are diverted to the sludge holding lagoons mentioned above and are treated and disposed of accordingly.

Filtered water passes through dual collection pipes which gravity transfers the water to the clear water reservoirs (2 x 2.2 ML reservoirs). Before reaching the clear water reservoirs, the dual collection pipes intersect at a pit designed to provide mixing, a water storage for the filter backwash pumps and also be used as a common dosing point for chlorine. Prior to entry into this pit filtered water is dosed with hydrated lime by one of two duty/standby lime feeding systems to correct pH (pH 7.8 target).

Although not currently dosed since the Council adopted to discontinue dosing in mid-2013, fluoride (sodium fluorosilicate 1 tonne bulk bag system) if dosed, is added via dual duty/standby dosing pump skids into each of the dual collection pipes immediately downstream of the intersecting mixing pit. Fluoride dosing to a final concentration of 0.7 mg/L is achieved using flow-paced dosing based on flow readings from meters in the clear water collection pipes. On-line Dulcometer fluoride analysers are installed for each dosing pump set with interlocks with a separate PLC to prevent overdosing and with low, high and high high alarm setpoints to detect excursions outside of the target operating range (0.6 to 0.86 mg/L). The same alarm setup exists on a third final water Dulcometer fluoride analyser to provide redundancy of on-line analysis. This final water on-line analyser is not interlocked with the PLC that controls the two dosing pump sets.

Disinfection is achieved by adding chlorine gas into the pit via one of two duty/standby Siemens gas feed chlorinators. The chlorine gas storage room is designed to allow four cylinders containing 920 kg each to be connected for use at any time. A free chlorine residual setpoint of 1.1 mg/L is used for the final water and this is achieved using flow-paced dosing at rates of more than 8 kg/h of chlorine gas if required to achieve the free chlorine residual setpoint. Water from the clear water reservoirs is then pumped to the distribution system using the High Lift Pump Station on site. Alarm setpoints for low, low low, high and high high alarms for the free chlorine residual are in place to detect excursions outside of a target range (0.5 to 1.5 mg/L of free chlorine) and the Glenmore WTP PLC is programmed to automatically shutdown the WTP and High Lift Pump Station if the free chlorine residual exceeds 1.7 mg/L for more than 30 minutes. If the free chlorine residual triggers a low level alarm urgent action is taken to address the cause of the excursion via the attendance to site of suitably qualified reactive maintenance staff. If required the WTP will be shutdown to prevent the distribution of non-disinfected water to customers.

As indicated above, the Glenmore WTP has a maximum treatment capacity of 120 ML/d. This maximum capacity is based on the recorded peak operating rate used in the early 2000s when demand before the implementation of water meters in Rockhampton was significantly higher than it is currently. Each sedimentation tank is capable of achieving effective clarification of raw water at a rate of 70 ML/d. The 10 rapid sand filters are capable of achieving effective filtration of clarified water at a

flow rate of 120 ML/d. The chlorine gas disinfection system is capable of achieving effective disinfection up to at least 120 ML/d.

Despite these stated maximum capacity rates, a safe working maximum treatment capacity of 115 ML has been adopted as the normal maximum flow rate through the Glenmore WTP. Therefore current maximum loadings are well beneath the known effective capacity of the sedimentation tanks, filters and disinfection process steps and no bypasses for any of these steps exists in the WTP process design. This rate has been determined based on its suitability over a range of differing raw water quality conditions. If required to meet high demand or maximise the cost effectiveness of operating during the off-peak electricity period, the Glenmore WTP is operated at the 110 ML/d flow rate, however, much of the time when demand is low, the flow rate through the Glenmore WTP ranges between 60 and 85 ML/d.

The Glenmore WTP is attended by at least one operator all day every day in order to closely monitor and operate (if required) the Glenmore WTP as well as to perform a range of water quality and process performance tests and checks.

2.3.2 Mount Morgan Water Treatment Plant

The Mount Morgan Water Treatment Plant consists of an AQUAPAC package plant (Aquagenics Pty Ltd) that incorporates coagulation, flocculation, sedimentation and gravity filtration in a single tank system. This plant commenced operation in 1994 and has a design flow capacity of 30 L/sec (~2.6 ML/d).

Figure 2.5 shows a schematic representation of the treatment process used at the Mount Morgan WTP. The incoming raw water is dosed with powdered activated carbon to assist with the removal of soluble organics and colour. The coagulant aluminium sulphate prepared in a batch mixing tanks is dosed using a duty/standby dual pump system into the inlet pipework. Coagulant dosed water then enters the vacuum chamber which is designed to provide rapid mixing conditions through intermittent high flows into the dosing manifold of the clarifier. The inlet pipework is also equipped with a single pump system and dosing point for the addition of potassium permanganate to pre-oxidise iron and manganese which is often present at elevated concentrations in the raw water sourced from Fletcher Creek. Fletcher Creek is rarely used as the source of raw water since the increase in the storage capacity of No. 7 Dam in 1999.

Clarification is achieved when the 'pulsed' intermittent high flows expand the sludge blanket then longer quiescent periods allow the sludge blanket to settle. As the coagulant dosed water passes through the dense sludge blanket, flocs and other particles collide to promote the flocculation and sedimentation process. Clarification also includes the use tube settlers to promote the sedimentation of fine floc particles and reduce carry-over of fine flocs to the filters. The tube settlers are located above the sludge blanket in the clarification tank. The sludge blanket depth is maintained by a sludge hopper which is designed to act as a sludge concentrator to collect excess sludge. Sludge is removed through a manual or automated desludging process to on-site storage ponds where the sludge is gravity settled and the supernatant is either evaporated to avoid any possible impact on Mount Morgan WTP water quality or if required is transferred to a storage tank before being returned to the plant inlet.

Figure 2.5: Schematic Representation of the Treatment Process at the Mount Morgan WTP.

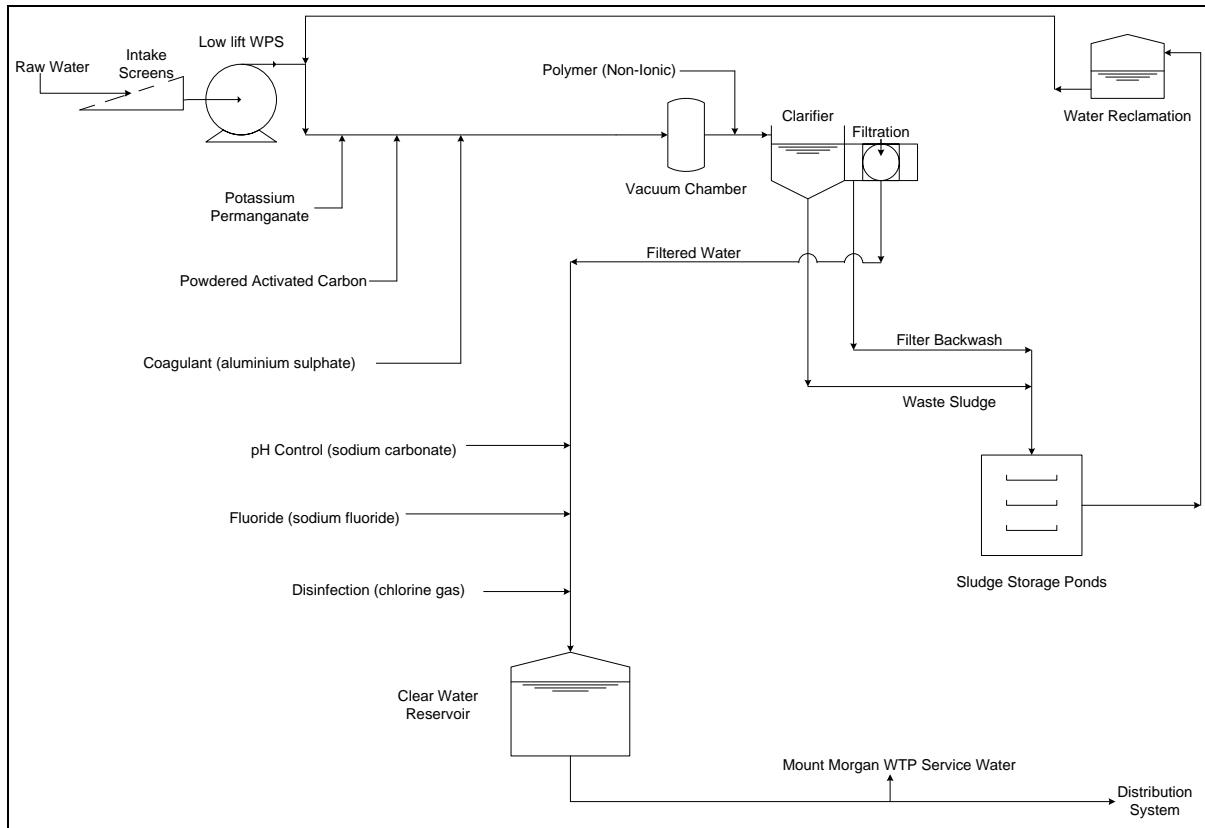

Clarified water is collected into launders through perforated pipes located above the tube settlers and is then transferred to the two rapid gravity sand filters for filtration. Each filter has a total bed depth of 700 mm made up of a 300 mm top layer of anthracite (effective size = 1.6-1.7 mm) above a 300 mm layer of silica sand (effective size = 0.6-0.7 mm) which is above a 100 mm layer of coarse silica sand (effective size = 1.1-1.5 mm). Filters are backwashed automatically or manually using a single backwash pump system and single blower system to air scour and wash each filter every 24-36 hours of plant operation. Backwash water is stored in an on-site lagoon where it is settled and then transferred to a storage tank before being returned to the plant inlet.

Filtered water is dosed with sodium carbonate mixed in a chemical batching tank to correct pH (target pH = 7.8) using a single pump dosing system and is then gravity fed to the on-site clear water reservoir (2.5 ML total storage volume). A sodium fluoride saturator plant doses the filtered water to achieve the 0.7 mg/L target concentration. The filtered water is chlorinated using chlorine gas as it enters the clear water reservoir (Black St Reservoir) which also provides half of the service reservoir storage for the Mount Morgan Water Supply Scheme. The Siemens chlorinator is designed to dose chlorine gas at the rate required to achieve a free chlorine residual of 1.5 mg/L in the clear water reservoir. The dosing is flow paced and also includes dosing control based on the on-line measurement of free chlorine residual.

Alarm setpoints for low, low low, high and high high alarms for the free chlorine residual are in place to detect excursions outside of a target range.

Although not currently dosed since the Council adopted to discontinue dosing in mid-2013, fluoride dosing to 0.7 mg/L, if required, is achieved using a sodium fluoride saturator dosing plant installed in accordance with the Fluoridation Code of Practice. This dosing system is controlled by a PLC that operates independently to the main WTP PLC. The same on-line monitoring and alarm setpoints as listed for the Glenmore WTP and Woodbury WTPs are in place at the Mount Morgan WTP.

The plant operation is currently controlled by an Allen Bradley CompactLogix PLC that provides automated operation of plant starting and stopping, filter backwashing and de-sludging processes. On-line monitoring of a number of water quality parameters is now available at the Mount Morgan WTP with pH, turbidity and electrical conductivity monitored in raw water, filtered water and final water.

The Mount Morgan WTP is designed with all process steps able to achieve effective operation at a maximum capacity of 2.6 ML/d or a peak instantaneous flow of 30 L/sec with no option to bypass any of the treatment steps. The Mount Morgan WTP is operated at a constant flow rate of approximately 22 L/sec, well beneath the design capacity of the WTP to help ensure stability and consistency of chemical dosing and plant performance. Current water demand is being met easily at this constant flow rate with consumption usually between 0.9 and 1.3 ML/d.

The Mount Morgan WTP is attended by an operator for at least two hours each day in order to closely monitor and operate (if required) the Mount Morgan WTP as well as to perform a range of water quality and process performance tests and checks.

2.4 Availability of Equipment and Critical Spares

For all WTP and water distribution infrastructure an extensive inventory of equipment and critical spares is kept locally for most of the components of existing water treatment and distribution infrastructure. Table 2.4 provides an indication of the spares kept and provides a description of the type or function of the components.

Standard designs and equipment specifications have been adopted where possible to improve the consistency of processes, and to reduce the number of spares that need to be kept to meet maintenance demands. Critical equipment such as on-line and bench-top water quality monitoring instrumentation, chemical dosing pumps, flow meters, ultrasonic level indicators, PLCs and radio telemetry systems are among the items for which standard design and equipment specifications have been adopted. Future infrastructure upgrades are planned in accordance with these adopted specifications.

A significant amount of redundancy has been designed into the WTPs. Items of equipment such as air compressors, chemical storage tanks, chemical batch tanks, mixers and dosing pumps, flow meters and flow switches have been installed in either duty/standby or in an arrangement which provides a level of backup redundancy to help ensure continuity of operation.

Table 2.5: Critical Spares Kept for Water Treatment and Distribution Infrastructure

Equipment Category	Type of Equipment/Parts in Each Category
Mechanical	Compressor and pneumatic system spares Pumps for process sampling or chemical dosing Backup generator set spares Mixers for chemical batching tanks Valves and valve actuator spares
Electrical	Switching gear and spares for high lift and low lift pump stations Programmable Logic Controller spares Electrical components, contactors, flow switches, circuit breakers Radio telemetry equipment and spares Variable speed drives and spares
Process Control	SCADA servers and spares Flow meters, flow meter head units, flow sensors On-line instrument probes, ultrasonic level indicators

2.5 Water Distribution and Reticulation Infrastructure

A summary of the operation and flow regime through the water distribution system is provided below for each of the three water supply schemes that are supplied fully or partially with water by Fitzroy River Water. The three drinking water schemes are comprised of a range of different assets that are used to store, re-chlorinate and distribute water to customers. In all three schemes a combination of gravity and pumped distribution mains are used to ensure flow and pressure requirements are met. A detailed description of the below ground pipe infrastructure, the above ground reservoirs and re-chlorination facilities, and water pump stations that are required to transport water and pressurise supply zones is also provided. Specific details of these assets in each scheme are provided in Tables 2.6 to 2.8.

2.5.1 Overview of Operation – Rockhampton Water Supply Scheme

The Glenmore high-lift water pump station (WPS) pumps water from the WTP through a network of trunk distribution mains to fill the Birkbeck Avenue, Yaamba Road, Thozet Road and Athelstane Range Reservoirs (see Figure 1). Each of these reservoirs gravity feed water to the surrounding reticulation networks in North Rockhampton. The Belmont Road WPS lifts water to the Samuel Crescent Reservoir which then gravity feeds a small reticulation network near the Glenmore WTP.

The Norman Road WPS is used to fill the Nagle Drive Reservoir which gravity feeds the Norman Gardens reticulation zone in North Rockhampton. The Thozet Road WPS lifts water from the Thozet Road Reservoir to fill the Forbes Avenue and Rogar Avenue Reservoirs which then gravity feeds water to the surrounding reticulation that serves the Frenchville area of North Rockhampton. A series of three small WPS are used to lift water to the Mt Archer Reservoir (approximately 600 m elevation) which then gravity feeds a small reticulation system on the top of Mt Archer. To the east of

the Thozet Rd Reservoir, a trunk main supplies water to a privately owned and operated reservoir used to supply water to two abattoirs.

The Athelstane Range Reservoir Complex gravity feeds water to the South Rockhampton and West Rockhampton reticulation networks as well as supply water along a gravity trunk main to the town of Gracemere where the Old Capricorn Highway WPS lifts the water to fill the Mawdesley Hill Reservoirs. Water is then gravity fed from the Mawdesley Hill Reservoirs to the surrounding reticulation system and also to the Lucas Street Reservoir which supplies the reticulation system on the south-western side of Gracemere.

The Yaamba Road Reservoir gravity feeds water to the Parkhurst area and the Ramsay Creek WPS which lifts water to supply the Glenlee, Glendale, Rockyview and Etna Creek areas as well as filling the Mt Charlton Reservoir and supplying The Caves WPS which fills The Caves Reservoir. The Caves and Mt Charlton Reservoirs also gravity feed the same areas to the north of the Ramsay Creek WPS. All these localities to the north of Ramsay Creek are now currently part of Livingstone Shire Council which owns and operates the water distribution infrastructure in these areas.

The newly constructed Ibis Avenue WPS pumps water from the Yaamba Road Reservoir along the Rockhampton to Yeppoon Water Supply Pipeline to the Boundary Hill Reservoir located halfway between Rockhampton and Yeppoon. From here, the water is gravity fed through the Yeppoon West Valve Facility to either the St Faith's or Taranganba Reservoirs in the Capricorn Coast Water Supply Scheme. The Boundary Hill Reservoir is owned by Rockhampton Regional Council and operated by Fitzroy River Water and the pipeline infrastructure on the Yeppoon side of the Boundary Hill Reservoir is owned and operated by Livingstone Shire Council. All arrangements relating to the supply of this water are as per the Operating Protocol which forms part of the commercial water supply agreement between Rockhampton Regional Council and Livingstone Shire Council. A copy of this Operating Protocol is provided in Appendix C.

Details of the material type, age and length of water distribution pipes is provided in Table 2.6 below. The water distribution pipe infrastructure includes a range of different material types and ages. Details of the service reservoirs used to supply the distribution and reticulation systems are provided in Table 2.7.

Drinking water is rechlorinated at a number of locations throughout the distribution system. A list of rechlorination facilities and details of their design is provided in Table 2.8. All rechlorination facilities are monitored using the SCADA system through a radio telemetry network.

Details of the location, purpose and design of WPS are provided in Table 2.9.

2.5.2 Overview of Operation – Capricorn Coast Water Supply Scheme

Drinking water is supplied to the Capricorn Coast Water Supply Scheme from the Glenmore WTP via the Boundary Hill Reservoir as described in the overview for the Rockhampton Water Supply Scheme above, from the Woodbury WTP or through the combination of supply from each of these two WTPs.

Currently, approximately 25-30% (usually a minimum of 3 ML per day) of the Capricorn Coast Water Supply Scheme demand is supplied with water from the Glenmore WTP via the Rockhampton to Yeppoon Water Supply Pipeline with the

remaining supply coming from the Woodbury WTP. The existing infrastructure allows for a number of supply permutations with varied contributions from each source and associated WTP. Figure 2.6 provides a schematic overview of the main options including the current split scheme operating arrangement for supply to the Capricorn Coast Water Supply Scheme. As indicated above, the supply of water by Rockhampton Regional Council to Livingstone Shire Council is carried out in accordance with agreed terms and conditions as specified in the current commercial water supply agreement. A copy of the Operating Protocol included in this agreement is provided in Appendix C. Once the water is supplied to Livingstone Shire Council from the Boundary Hill Reservoir, it is supplied to the various parts of the Capricorn Coast Water Supply Scheme according to the operating regime that is implemented and controlled by Livingstone Shire Council.

The existing infrastructure enables the Capricorn Coast Water Supply Scheme to be supplied either solely by the Glenmore WTP, solely by the Woodbury WTP or via a split scheme arrangement where the Glenmore WTP and Woodbury WTP supply water to the northern and southern part of the scheme respectively. The management of the distribution of water supplied by each of the Woodbury and Glenmore WTPs is the responsibility of Livingstone Shire Council. As required though, the Livingstone Shire Council will take as much water from the Boundary Hill Reservoir as they require, to meet demand during periods where either demand exceeds the supply capacity of the Woodbury WTP or when the operation of the Woodbury WTP is suspended for the completion of maintenance.

Specific details of pipe materials, reservoirs and water pump stations are no longer provided in Tables 2.6 to 2.9 as these details are no longer part of the responsibility of Fitzroy River Water with these assets now owned by Livingstone Shire Council.

2.5.3 Overview of Operation – Mount Morgan Water Supply Scheme

Drinking water produced at the MMWTP is gravity fed into the Black Street Reservoir which also serves as the clear water reservoir for the WTP. From here the water is gravity fed to the reticulation system in the Mount Morgan and Baree areas. Water is pumped by the East Street WPS to fill the North Street Reservoir. These two 2.5 ML reservoirs are typically used to supply the northern and southern parts of the reticulation respectively. A number of pressure reducing valves and booster WPS are used to maintain appropriate water pressure in low and high elevation areas within the Mount Morgan Water Supply Scheme. The use of pressure reducing valves is needed to cater for the range of changes in elevation throughout the distribution network and also to avoid over-pressuring of some relatively old underground assets to prevent pipe breaks.

Details of the material type, age and length of water distribution pipes is provided in Table 2.6 below. The water distribution pipe infrastructure includes a range of different material types and ages. Details of the service reservoirs used to supply the distribution and reticulation systems are provided in Table 2.7.

Drinking water is re-chlorinated at the North Street Reservoir. Details of the design of this re-chlorination facility are provided in Table 2.8. This re-chlorination facility is monitored using the SCADA system through a radio telemetry network.

Details of location, purpose and design of WPS are provided in Table 2.9.

Figure 2.6: Overview of Supply Scenarios for Supplying Water to the Capricorn Coast Water Supply Scheme.

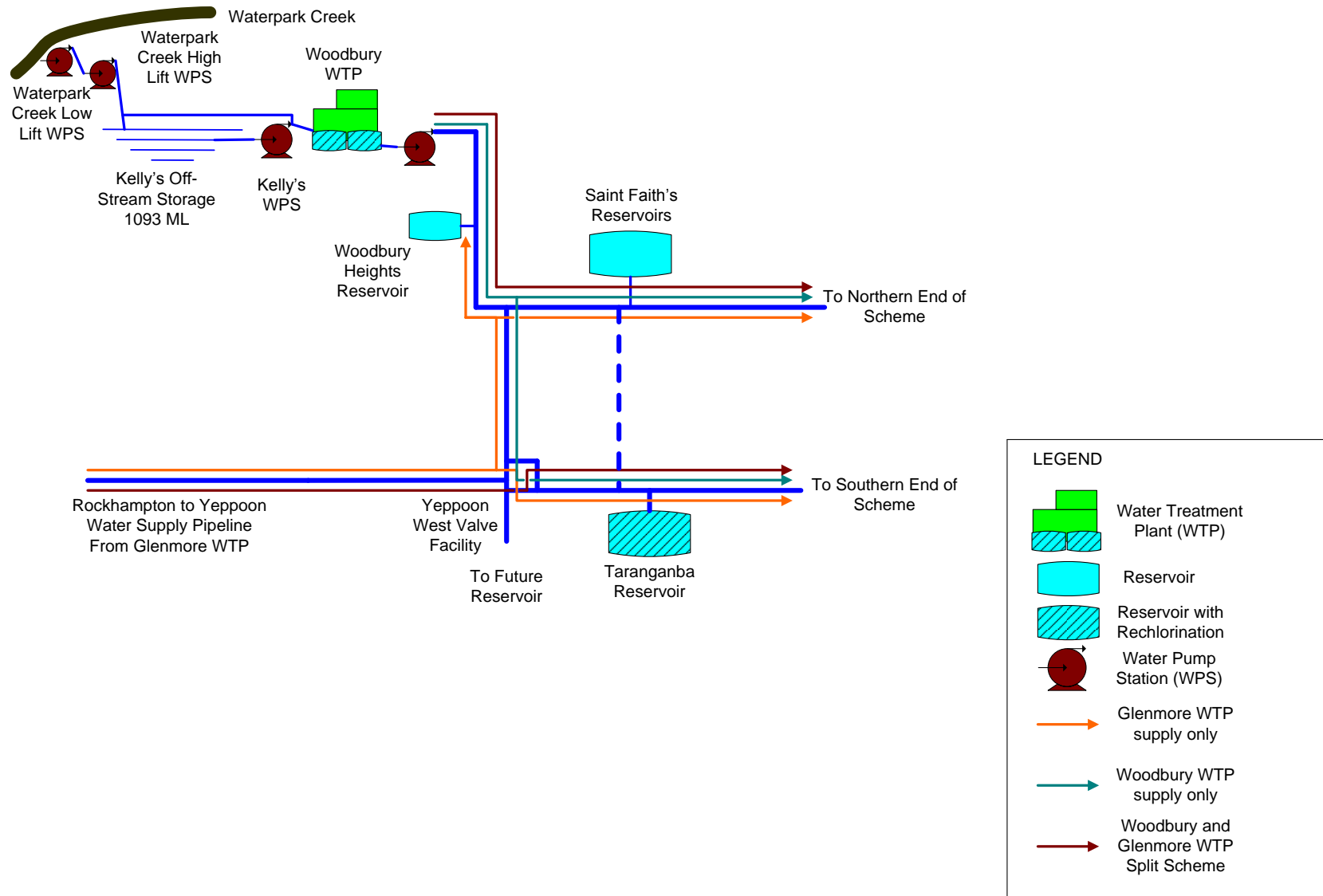

Table 2.6: Details of Pipeline Infrastructure in each Drinking Water Supply Scheme

Material	Length (km)	Year Constructed
Rockhampton Water Supply Scheme		
AC	168	1920-1986
CI	113	1920-1970
GI	4	1948-1952
PE	41	1970-2014
mPVC	100	2002-2011
uPVC	175	1992-2002
MSCL	31	1950-2007
DICL	15	1980-2014
oPVC	11	2008-2014
Mount Morgan Water Supply Scheme		
AC	17	1948
CICL	10	1948-1952
uPVC	13	1992-2002
mPVC	15	2008-2014
MSCL	7	1952
PE	9	1965-2014
GI	1	1948-1952

AC = asbestos cement, CI = cast iron, PE = polyethylene, mPVC = modified polyvinyl chloride, uPVC = unplasticised polyvinyl chloride, MSCL = mild steel cement lined, DICL = ductile iron cement lined, oPVC = oriented polyvinyl chloride, CICL = cast iron cement lined, GI = galvanised iron

Table 2.7: Details of Drinking Water Reservoirs in each Water Supply Scheme

Reservoir Name	Year Built	Capacity (ML)	Type/Design	Roof
Rockhampton Water Supply Scheme^a				
Birkbeck Ave.	1999	12.2	Concrete circular reservoir	Fully enclosed metal sheet
Samuel Crescent	1993	0.34	Steel panel circular reservoir	Fully enclosed metal sheet
Yaamba Rd	1974	13.7	Concrete circular reservoir	Fully enclosed metal sheet
Mt Charlton	1925	9.0	Concrete rectangular reservoir	Partially enclosed metal sheet
The Caves 1 & 2	1985	2 x 0.1	2 x Concrete circular reservoir	Fully enclosed concrete
Nagle Drv.	1986	10.2	Concrete circular reservoir	Fully enclosed metal sheet
Thozet Rd	1963	9.0	Steel plate circular reservoir	Fully enclosed metal sheet
Forbes Ave.	1976	4.5	Concrete circular reservoir	Fully enclosed metal sheet
Rogar Ave.	2004	7.0	Concrete circular reservoir	Fully enclosed concrete
Mt Archer	1974	0.27	Concrete circular reservoir	Fully enclosed concrete
Athelstane A	1958	4.5	Concrete circular reservoir	Fully enclosed metal sheet
Athelstane B	1958	4.5	Concrete circular reservoir	Fully enclosed metal sheet
Athelstane C	1932	9.1	Concrete rectangular reservoir	Fully enclosed fibro sheet
Athelstane D	1996	20.0	Concrete circular reservoir	Fully enclosed metal sheet
Mawdesley Hill 1	1986	1.5	Concrete circular reservoir	Fully enclosed metal sheet
Mawdesley Hill 2	1993	1.5	Concrete circular reservoir	Fully enclosed metal sheet
Mawdesley Hill 3	1972	1.0	Concrete circular reservoir	Fully enclosed metal sheet
Lucas St	2004	3.75	Concrete circular reservoir	Fully enclosed metal sheet
Boundary Hill	2010	10	Concrete circular reservoir	Fully enclosed concrete
Mount Morgan Water Supply Scheme				
Black St	1955	2.5	Concrete circular reservoir	Fully enclosed metal sheet
North St	1993	2.5	Concrete circular reservoir	Fully enclosed fibro sheet

^a Note that the Mt Charlton and The Caves reservoirs are now owned and operated by Livingstone Shire Council.

Table 2.8: Reservoir Re-chlorination Facilities and Details of the Disinfection System at each Site

Reservoir Name	Disinfectant Type	Year Installed	Dosing Mode/Design	Target Residual (mg/L)	Monitoring/Alarms	Pump Setup
Rockhampton Water Supply Scheme						
Birkbeck Ave	Sodium hypochlorite	1999	Inlet flow paced, Cl analyser, Overdose auto shut-off, Telemetry to SCADA	1.0	Residual & Hypo tank level Low, Lo Low, High, Hi High,	Single Dosing Pump, Recirculation Pump
Yaamba Rd	Chlorine gas	1993	Inlet flow paced, Cl analyser, High dose auto shut-off, Telemetry to SCADA	1.0	Residual & Gas Weight Low, Lo Low, High, Hi High,	Not applicable
Nagle Drv	Sodium hypochlorite	2011	Inlet flow paced, Cl analyser, High dose auto shut-off, Telemetry to SCADA	1.0	Residual & Hypo tank level Low, Lo Low, High, Hi High	Single Dosing Pump, Recirculation Pump
Mt Charlton	Sodium hypochlorite	2009	Inlet flow paced, Cl analyser, High dose auto shut-off, Telemetry to SCADA	1.0	Residual & Hypo tank level Low, Lo Low, High, Hi High	Single Dosing Pump, Recirculation Pump
Thozet Rd	Sodium hypochlorite	1993	Inlet flow paced, Cl analyser, High dose auto shut-off, Telemetry to SCADA	1.0	Residual & Hypo tank level Low, Lo Low, High, Hi High	Single Dosing Pump, Recirculation Pump
Athelstane	Sodium hypochlorite	1992	Inlet flow paced, Cl analyser, High dose auto shut-off, Telemetry to SCADA	1.0	Residual & Hypo tank level Low, Lo Low, High, Hi High	Single Dosing Pump, Recirculation Pump
Mawdesley Hill	Sodium hypochlorite	2007	Inlet flow paced, Cl analyser, High dose auto shut-off, Telemetry to SCADA	1.0	Residual & Hypo tank level Low, Lo Low, High, Hi High	Single Dosing Pump, Recirculation Pump
Lucas St	Sodium hypochlorite	2004	Inlet flow paced, Cl analyser, High dose auto shut-off, Telemetry to SCADA	1.0	Residual & Hypo tank level Low, Lo Low, High, Hi High	Single Dosing Pump, Recirculation Pump
Boundary Hill	Sodium hypochlorite	2010	Inlet flow paced, Cl analyser, High dose auto shut-off, Telemetry to SCADA	1.0	Residual & Hypo tank level Low, Lo Low, High, Hi High	Duty/Standby Dosing Pump, Recirculation Pump
Mount Morgan Water Supply Scheme						
North St	Sodium hypochlorite	2014	Inlet flow paced, Cl analyser, High dose auto shut-off, Telemetry to SCADA	1.0	Residual & Hypo tank level Low, Lo Low, High, Hi High	Single Dosing Pump, Recirculation Pump

Table 2.9: Details of Water Pump Stations within Drinking Water Supply Schemes

Pump Station Name	Purpose	Pump Capacity L/sec	Pump Station Design [#]
Rockhampton Water Supply Scheme			
Glenmore Low Lift	Supply raw water to the Glenmore WTP	715, 270, 270, 560	4 Centrifugal pumps, SCADA monitored
Glenmore High Lift	Supply potable water to RWSS	270, 270, 270, 560, 560	5 Centrifugal pumps, SCADA monitored
Agnes St	Boost pressure to high zone	270, 110, 190	3 centrifugal pumps, SCADA monitored
Birkbeck Drive	Supply water to the future Edenbrook Estate	30, 30, 30	3 centrifugal pumps, SCADA monitored
Everingham Ave	Boost pressure to high zone	11, 11, 11	3 centrifugal pumps, SCADA monitored
Frenchville Rd	Boost pressure to high zone	1, 1, 1, 1	4 centrifugal pumps, not monitored
Mt Archer 1,2,3,4	Lift water to Mt Archer (~600m elevation)	All 3.4	2 centrifugal pumps, SCADA monitored
Norman Rd	Fill Nagle Drive Reservoir	57, 57	2 centrifugal pumps, SCADA monitored
Ramsay Ck	Fill Mt Charlton Reservoir, Supply to reticulation	60, 60	2 centrifugal pumps, SCADA monitored
Ridgedale Ave	Boost pressure to high zone	4	1 centrifugal pump, not monitored
Samuel Crs.	Boost pressure to high zone	11,11	2 centrifugal pumps, SCADA monitored
Yaamba Rd	Boost pressure to high zone	23, 23	2 centrifugal pumps, not monitored
Belmont Rd	Fill Samuel Crs Reservoir	11, 11, 11	3 centrifugal pumps, SCADA monitored
Bloxsom St	Boost pressure to high zone	7, 7	2 centrifugal pumps, SCADA monitored
Braddy St	Boost pressure to high zone	29, 29	2 centrifugal pumps, SCADA monitored
The Caves	Fill The Caves Reservoir	5, 5	2 centrifugal pumps, SCADA monitored
Forbes Ave	Boost pressure to high zone	0.5, 0.5	2 centrifugal pumps, SCADA monitored
Guymer St	Boost pressure to high zone	10, 10	2 centrifugal pumps, SCADA monitored
Ibis Ave.	Supply water to Boundary Hill Reservoir	250, 250	2 centrifugal pumps, SCADA monitored
Lakes Ck Rd	Fill third party Reservoir, Supply to reticulation	30, 30	2 centrifugal pumps, SCADA monitored
Rockonia Rd	Boost pressure to high zone	25, 25	2 centrifugal pumps, SCADA monitored
Selwyn Crs	Boost pressure to high zone	1, 1	2 centrifugal pumps, not monitored
Sleipner St	Boost pressure to high zone	1.7	1 centrifugal pump, not monitored
Thozet Rd	Fill Forbes and Rogar Reservoirs	120, 120	2 centrifugal pumps, SCADA monitored
Wehmeier Ave	Boost pressure to high zone	20	1 centrifugal pump, SCADA monitored
Whiteley St	Boost pressure to high zone	0.5	1 centrifugal pump, not monitored
Davison St	Boost pressure to high zone	10, 10, 10	3 centrifugal pumps, SCADA monitored
Lucas St	Boost reticulation pressure	45, 45, 45	4 centrifugal pumps, SCADA monitored
Old Capricorn Hwy	Fill Mawdesley Hill Reservoir	115, 115	2 centrifugal pumps, SCADA monitored
Mount Morgan Water Supply Scheme			
Dam	Supply raw water to Black St WPS	25	1 submersible pump, SCADA monitored
Black St	Supply raw water to MMWTP	24, 24	2 centrifugal pumps, SCADA monitored

Pump Station Name	Purpose	Pump Capacity L/sec	Pump Station Design [#]
Fletcher Ck	Supply raw water to MMWTP	25, 30	2 centrifugal pumps, SCADA monitored
Baree St	Boost pressure to high zone	0.6	1 centrifugal pump, not monitored
Darcy St	Boost pressure to high zone	0.6	1 centrifugal pump, not monitored
East St	Boost pressure to high zone	3	1 centrifugal pump, not monitored
Hall St	Boost pressure to high zone	0.6	1 centrifugal pump, not monitored
Horse Ck	Boost pressure to high zone	0.6	1 centrifugal pump, not monitored
Hamilton Ck	Boost pressure to high zone	0.6	1 centrifugal pump, not monitored
William St	Boost pressure to high zone	0.6	1 centrifugal pump, not monitored

[#]All pump stations with multiple pumps operate as Duty/Standby pumps except the Low Lift and High Lift WPS in the Rockhampton Water Supply Scheme

2.5.4 Known Areas of Low Pressure within Distribution Systems

Due to recent improvements in pressure management in Mount Morgan there are no significant portions of this distribution system which possess less than the minimum service pressure standard of 220 kPa.

2.5.5 Known Areas of Long Detention Time within Distribution Systems

There are two locations within the drinking water schemes where Fitzroy River Water is involved partially or fully in the management of water quality, where the size and length of water supply pipelines leads to long detention times that result in a drinking water age in excess of 5 days.

The most significant of these is the Rockhampton to Yeppoon Water Supply Pipeline which is comprised of approximately 40 km of 600 mm or 750 mm diameter water trunk infrastructure. The Boundary Hill Reservoir (10 ML) is located at close to the mid-point of this length of pipeline. The combined storage capacity of the pipeline and the reservoir is approximately 24 ML. The daily volume of supply from the Glenmore WTP along the pipeline to the Capricorn Coast Water Supply Scheme is usually between 3 and 5 ML. Based on this rate of supply the water may take in excess of 5 days before it travels from the WTP to the first customer's tap.

Finally, the rising main between Ramsay Creek WPS and the Mt Charlton Reservoir to the north is another area where due to the length (~18 km) and diameter of the pipe (~600 mm), distributed water can have a relatively long detention time depending on demand. The overall operation of this part of the Rockhampton Water Supply Scheme north of Ramsay Creek Water Pump Station is the responsibility of Livingstone Shire Council.

2.6 Stakeholders Involved in Managing Drinking Water Infrastructure

Apart from FRW staff, other groups, companies or organisations are involved in the management of the infrastructure and water quality associated with drinking water services provided by RRC. Table 2.10 contains a list of these stakeholders, the infrastructure they are involved in managing and their contribution as a stakeholder.

Table 2.10: Stakeholders Involved in the Management of Drinking Water Quality and Infrastructure

Name of Stakeholder	Infrastructure Involved	Stakeholder Contribution
All Water Supply Schemes		
Department of Natural Resources and Mining	Water sources and catchments	Water quality and quantity monitoring and management
Department of Environment and Heritage Protection	Water sources and receiving environments and associated catchments	Regulator for protection of the environment.
Office of the Water Supply Regulator	All of scheme infrastructure	Regulator of drinking and recycled water schemes, incident management
Queensland Health	All of scheme infrastructure	Primary responsibility for public health, incident management
Rockhampton Water Supply Scheme		
Fitzroy Basin Association Incorporated	Fitzroy Basin upstream catchment	Catchment management and water quality monitoring
Fitzroy Water Quality Advisory Group	Fitzroy Basin upstream catchment	Advisory function for monitoring and environmental management
Fitzroy Partnership for River Health	Water sources and catchments	Water quality monitoring and reporting.
Teys Brothers Pty Ltd	Reticulation supply to abattoir	Major commercial customer
SunWater	Eden Bann Weir and other upstream storages	Management of catchment and storage releases
Capricorn Coast Water Supply Scheme		
Livingstone Shire Council	All of scheme infrastructure	All aspects of water service provision
Fitzroy River Water	Boundary Hill Reservoir	Bulk supply of drinking water from the Glenmore WTP
Mount Morgan Water Supply Scheme		
Smalls Egg Farm	Reticulation to Egg Farm	Major commercial customer
External Contractors/Suppliers		
Orica	WTPs and Reservoir Disinfection	Chlorine gas supplier
Omega Chemicals	WTPs	Coagulant chemical supplier
Redox	WTPs	Treatment chemical supplier
Elite Chemicals	WTPs and Reservoir Disinfection	Sodium hypochlorite supplier
Nalco	WTPs	Treatment chemical supplier
Activated Carbon Technologies	WTPs	Activated carbon supplier
Internal Contractors/Suppliers		
Logistics	All infrastructure	Assisting with procurement and logistics for all water operations
Business Services Team	All infrastructure	Assist with business management
Records Management	All infrastructure	Assist with data archiving
Customer Service Team	All infrastructure	Assist with customer interactions
Corporate Compliance	All infrastructure	Assist with Corporate reporting.

3 CATCHMENT AND WATER QUALITY INFORMATION

3.1 Catchment Characteristics

The three drinking water supply schemes described above that are either fully or partially supplied by Fitzroy River Water are supplied by a total of five separate surface water catchment systems. The surface catchments differ considerably with respect to size, volume of flow, topography, geology, vegetation, climate and land use. Only the surface water sources that are owned and operated by Fitzroy River Water are described below.

3.1.1 Fitzroy River Basin

The Fitzroy River Basin is an extensive and diverse catchment. It covers an area of Queensland of approximately 142,000 km² and consists of six major sub-catchments: Isaac/Connors, Nogoia, Comet, Mackenzie, Dawson and Fitzroy. A very detailed description of the Fitzroy River Basin is provided in the Fitzroy Basin Water Quality Improvement Report published by the Fitzroy Basin Association in 2008. In brief, the topography, geology, vegetation, climate and land use within the Fitzroy River Basin vary considerably.

Based on area, the predominant vegetation type is brigalow scrub (28%) which is characterised by a range of different softwood species which thrive on a variety of clay or loam soil types. Next most abundant (24%) is mountain and range topography which consists of medium to tall hardwood forests on the rocky more elevated terrain. Eucalypt woodlands (22%) are the next most abundant vegetation type and exist on a mix of sandy or loamy tableland or clay areas dominated by ironbark or related eucalypt species. Alluvial deposits covered by 'true gum' species such as blue gums and red gums as well as some poplar box and brigalow scrub cover 16% of the catchment. The remaining 10% is covered by bluegrass downs with open woodlands (7%), sandy areas dominated by cypress, shrubby and heath species (2%), and the coastal sandy margins that include eucalypt, teatree, sand dune and marine vegetation types (1%).

Average annual rainfall across the catchment ranges between 600 mm in the west, 800 mm in the east and 1000 mm in the north. Despite these rainfall averages, seasons are highly variable with long dry periods usually punctuated by short periods of high rainfall (usually in the summer months) which lead to high flows and flooding events. In some parts of the basin drought occurs on average every three years. As a result, 29 dams and weirs have been constructed throughout the basin to improve water availability for agriculture, industrial and urban uses. Isolated bushfires are common during dry periods and occur especially during late winter and early spring before the onset of summer rainfall.

Land use across the basin includes livestock grazing (81%), cropping (6%), conservation (6%), forestry (5%), urban (1%), mining (0.5%) and irrigation (0.5%). Grazing activities are widespread throughout the catchment including within a few kilometres of the Glenmore WTP along the banks of the Fitzroy River. Mining activities include the activities throughout the Bowen Basin to the west and north of the basin as well as in the lower parts of the Dawson River valley. Currently at least 43 coal mine operations exist within the basin. Mining activities are expected to increase over time with the establishment of new coal mines or coal seam gas

operations within the basin. The increased mining activities will inevitably lead to increased impacts on water quality in the basin. The extreme example of this impact was the release of mine-associated water from the Ensham Mine during 2008 under an emergency release arrangement. This emergency release led to sodium concentrations in excess of 100 mg/L in the Fitzroy Barrage Storage. It is estimated that coal mine water discharges contributed to between 18 and 25% of salinity loadings into the Fitzroy Basin at different times during 2011. Increased levels of total dissolved solids (TDS) such as sodium have the potential to negatively impact water aesthetics.

Rockhampton is the largest urban development in the basin. The towns of Emerald and Blackwater to the west of Rockhampton and the townships along the Dawson River and Isaac River are amongst the more developed areas of the basin. Urban development is expected to grow in response to increased mining activities in the region and the future construction of additional water storage on the Connors, Dawson and Fitzroy Rivers. Currently there is minimal impact from urban development, industrial activities or recreational activities on the located adjacent to Rockhampton on the water quality in the Fitzroy River Barrage storage. Urban development includes low level residential development, industrial activities include sand dredging and livestock grazing, and recreational activities are mainly limited to rowing and water skiing. These development activities have the potential to cause slight increases in turbidity (e.g. dredging) or microbial pathogen loads (e.g. from livestock) although there is no evidence to date that these activities are significantly impacting water quality in the Barrage storage.

3.1.2 Dee River and Fletcher Creek

The township of Mount Morgan and surrounding areas receive approximately 800 mm rainfall per year on average. The Dee River passes through the township of Mount Morgan. Although more famous for its highly coloured waters due to impacts caused by acid and metal pollution from the Mount Morgan mine site, the No. 7 Dam constructed on the Dee River just upstream of the town by the Mount Morgan Gold Mining Company is by contrast a relatively clean and undisturbed catchment. It is still however, an unprotected surface water with cattle grazing activities conducted upstream of the No. 7 Dam site in what is largely open eucalypt woodland on rocky soils through hilly terrain. The upper catchment of the Dee River contains minimal other urban, rural or industrial development or land use activities. It is possible that agricultural or grazing activities could impact the water quality in No. 7 Dam through the release of nutrients or microbial pathogens to the catchment. There is currently no evidence that these activities are having a negative impact on the quality of raw water in No. 7 Dam.

Fletcher Creek is located approximately 15 km to the south of Mount Morgan and is comprised of a small catchment that winds its way through a series of low hills that consist of open dry eucalypt woodlands and grasslands. The area is used predominantly for cattle grazing purposes with minimal other urban, rural or industrial development in the catchment area. The southern edge of the copper- and gold-bearing sulphide ore body that extends through to just north of Mount Morgan is located within a few kilometres of the Fletcher Creek weir. The sulphide ore body has no direct impact on the Fletcher Creek system, however, the slightly acidic soils create highly corrosive conditions for acid-sensitive metallic pipe materials.

The Mount Morgan area has not experienced significant levels of growth and development in recent years. The potential exists for the Mount Morgan mine to again become an active operation. Although this has the potential to lead to increased development and population growth in the township, this type of development does not appear likely to impact on either the upper Dee River or Fletcher Creek catchment areas.

3.2 Raw Water and Drinking Water Quality

Prior to the amalgamation of four Councils to form RRC in 2008, the analysis of raw water and drinking water quality was performed to varying degrees using a range of different approaches. In early 2009 a standardised approach to water quality monitoring was commenced across the existing drinking water schemes to ensure monitoring of raw water and drinking water quality was conducted appropriately. Since then, the operational and verification monitoring programs have been refined towards ensuring safe and reliable water supplies. These monitoring programs are defined in more detail in a later section.

The raw water sources and the treatment processes used to produce drinking water vary significantly among the schemes included in this DWQMP. Only the raw water sources, and their associated water quality, that are owned and operated by Fitzroy River Water are described in detail below.

3.2.1 Rockhampton Water Supply Scheme

As described above, the Fitzroy Basin is a very large and complex catchment system. The Fitzroy River raw water quality data presented in Table 3.1 reflects the size and complexity of the catchment. Of particular note is the massive range over which raw turbidity measurements have been recorded. High raw water turbidity occurs due to flow events in the river. The Dawson River catchment has historically been the greatest source of high turbidity raw water with values in excess of 2000 NTU recorded during flood events that occurred late last century.

The raw water also contains low background concentrations of fluoride. The specific source of the fluoride is unknown. Relatively high concentrations of iron and manganese have also been observed in the raw water. During a flood event that occurred in early 2010 raw water total iron concentrations of up to 14 mg/L were recorded. Similarly, a flood event in February 2013 recorded total manganese concentration above 0.5 mg/L.

Low levels of the cyanobacterial toxin cylindrospermopsin were detected during a bloom of *Cylindrospermopsis raciborskii* which occurred in 2009. This toxin-producing species of cyanobacteria is usually detected during prolonged periods of low raw water turbidity in late winter or early spring.

Testing for more than 20 different pesticides (see Appendix B) revealed the presence of many pesticides at or less than the limits of detection in the raw water. None of the pesticides were detected at concentrations above ADWG values.

Drinking water produced by the GWTP is of a very high quality and consistently meets ADWG. The value for final water turbidity (average = 0.41 NTU) is slightly higher than expected compared to the individual filter outlet turbidity measurements which rarely exceed 0.3 NTU. The slightly higher turbidity readings are due to the

addition of lime post-filtration. Disinfection by-product formation (e.g. trihalomethanes) in the Rockhampton Water Supply Scheme occurs with THM concentrations of approximately 150 µg/L towards the extremities of the scheme.

Table 3.1: Raw and Potable Water Quality Data for the Rockhampton Water Supply Scheme (average value shown with range shown in brackets)

Parameter	Unit	Fitzroy River Raw Water	Glenmore WTP Final Water
Nitrate	mg/L	0.11 (<0.01-2.2)	0.13 (<0.01-2.3)
Sulphate	mg/L	15.95 (0.32-96)	17 (2-42)
Fluoride	mg/L	0.14 (<0.10-0.20)	0.6 (<0.1-1.0)
Aluminium (acid-soluble)	mg/L	0.28 (<0.005-2.93)	0.02 (<0.005-0.14)
Boron	mg/L	0.05 (<0.03-0.05)	0.04 (0.03-0.07)
Copper	mg/L	0.0076 (<0.002-0.178)	0.0164 (0.002-0.171)
Iron	mg/L	1.81 (<0.01-21.6)	0.185 (<0.01-0.38)
Lead	mg/L	<0.001 (<0.001-0.005)	<0.001 (<0.0001-0.005)
Manganese	mg/L	0.07 (<0.01-0.58)	<0.001 (<0.0001-0.567)
Zinc	mg/L	0.015 (<0.005 – 0.06)	0.0102 (<0.005-0.028)
pH	pH units	8.07 (7.33-8.79)	7.99 (7.54-8.35)
Turbidity	NTU	114.07 (2.4-2030)	0.86 (0.10-3.5)
Trihalomethanes	µg/L	NT	59 (30-106)
Total Dissolved Solids	mg/L	253.7 (38-564)	246.11 (76-560)
Total Alkalinity	mg/L	93.38 (28-206)	91.92 (31-201)
Chloride	mg/L	58.74 (9.5-166)	65 (15-160)
Electrical Conductivity	µS/cm	386 (114-871)	395.74 (148-882)
Calcium	mg/L	18.5 (6-36)	20.83 (9.9-35)
Magnesium	mg/L	14.99 (3-52)	14.87 (2.9-51)
Potassium	mg/L	3.38 (1.8-5)	3.43 (2-5)
Sodium	mg/L	35.38 (12-79)	35.15 (9.4-82)
Total Hardness	mg/L	107.68 (28-289)	113.46 (40-285)
True Colour	Pt-Co	36.53 (2-100)	5 (1-13)
Silica	mg/L	18.78 (14-22)	17 (12-20)
Arsenic	mg/L	<0.001 (<0.001-0.002)	<0.001 (<0.001-0.001)
Cadmium	mg/L	<0.001 (<0.001)	<0.001 (<0.001)
Chromium	mg/L	<0.001 (<0.001-0.001)	<0.001 (<0.001-0.003)
Nickel	mg/L	0.002 (<0.001-0.005)	0.001 (<0.001-0.007)
Selenium	mg/L	<0.01 (<0.01)	<0.01 (<0.01)
Mercury	mg/L	<0.0001 (<0.001)	<0.001 (<0.001)
Total Organic Carbon	mg/L	15.58 (<1-127)	3 (<1-4)
Perfluorooctanoic Acid	µg/L	<0.02	<0.02
Perfluorooctane Sulphate	µg/L	<0.02	<0.02
<i>E. coli</i>	MPN/100ml	NT	<1 (<1)
<i>A. circinalis</i>	cells/ml	690 (340-1180)	0
<i>C. raciborskii</i>	cells/ml	2815 (0-46700)	40 (40)
Cylindrospermopsin	µg/L	0.4 (<0.2-0.9)	<0.2 (<0.2)
Microcystin	µg/L	<0.5	<0.5
Saxitoxins	µg/L	<2	<2
<i>Giardia</i> sp.	cysts/10L	<1 (<1)	<1 (<1)
<i>Cryptosporidium</i> sp.	oocysts/10L	<1 (<1)	<1 (<1)

Data obtained from sampling events from 2009 to 2013.

MPN = most probable number, NTU = nephelometric turbidity units, NT = not tested

Raw water quality in the Fitzroy River typically varies seasonally. This variation is usually flow dependent and is perhaps best illustrated by the changes in turbidity as flow events occur and then gradually decline over subsequent months. Figure 3.1 shows data for raw water turbidity at the Glenmore WTP between August 2010 and August 2011. During this period, the Fitzroy River changed from having no flow and low turbidity to an extended period of flow events and associated high turbidity from September 2010 onwards until the middle of 2011 before flows gradually reduced. The high and rapidly changing turbidity seen during this period is typical of these flow events which usually occur at least once a year. The Glenmore WTP effectively treats raw water with high turbidity due to its design and the use of the Pac 23 coagulant. When raw water turbidity decreases to levels less than 20 NTU or an extended period of time, the river can experience algal blooms which have the potential to affect water quality. The coagulant and polymer dosing rates are adjusted during algal bloom events to treat the water and filter operation is managed closely in order to optimise filter run time and performance during these events.

Figure 3.1: Changes in Fitzroy River raw water turbidity based on flow conditions from August 2010 to August 2011.

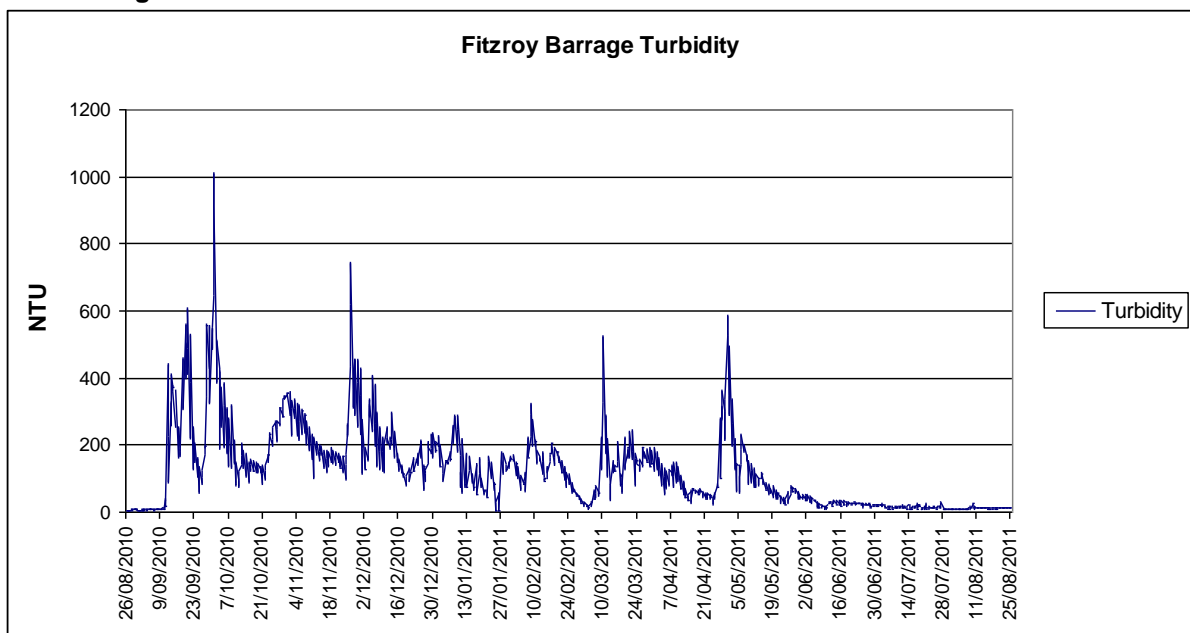
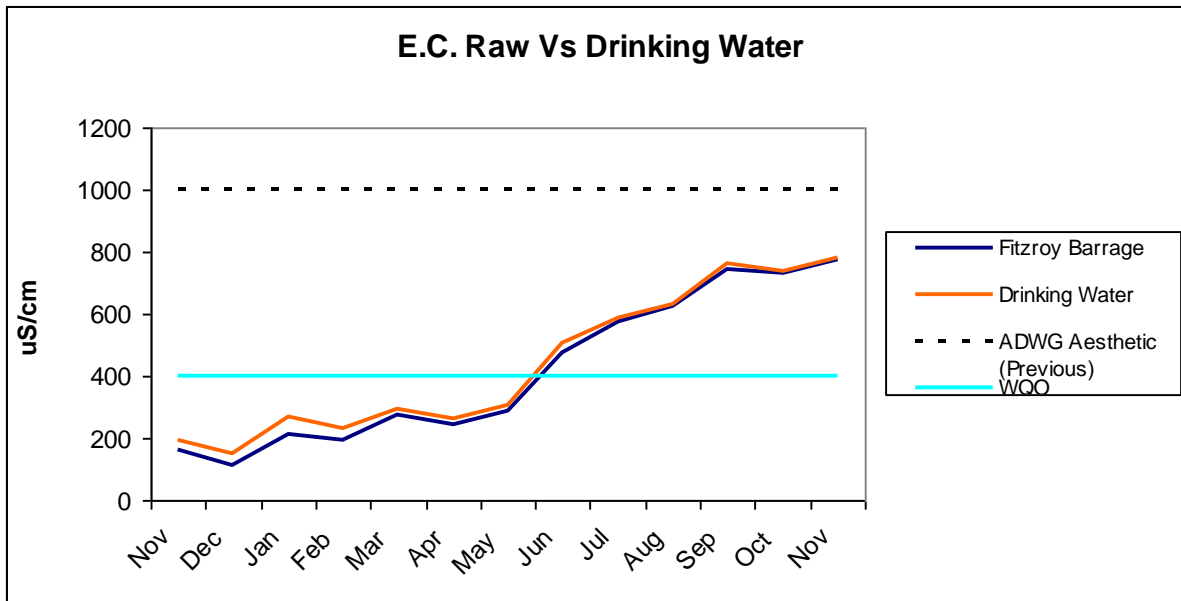

Figure 3.2: Electrical Conductivity data for raw water and drinking water at the Glenmore WTP between November 2010 to November 2011.



The Fitzroy Barrage raw water Electrical Conductivity (E.C.) also changes significantly due to events that occur upstream in the catchment. Figure 3.2 shows the changes in E.C. that occurred during the 12 month period from November 2010 to November 2011. Record rainfall in parts of the catchment saw the input of high levels of E.C. into the Fitzroy Basin from rising groundwater with high electrical conductivity. After the peak of the flood in the early 2011, high E.C. waters continued to flow downstream leading to a gradual increase in E.C. in the Fitzroy Barrage Storage.

3.2.2 Mount Morgan Water Supply Scheme

Raw water quality in the two available water sources No. 7 Dam and Fletcher Creek varies considerably. The water quality data presented in Table 3.3 show the contrasts between these two source waters. The No. 7 Dam raw water is typically of better quality than that available in the Fletcher Creek storage. A comparison of values for electrical conductivity for each source shows elevated values for Fletcher Creek due to the higher concentrations of calcium, magnesium and sodium in this raw water. The Fletcher Creek raw water also contains significantly higher concentrations of iron and manganese. Elevated concentrations of iron and manganese have previously challenged the performance of the Mount Morgan WTP. Because of the generally lower quality of its water and its relatively small storage size, the Fletcher Creek source is rarely used as raw water for the supply of drinking water to the Mount Morgan Water Supply Scheme.

Table 3.3: Raw and Potable Water Quality Data for the Mt Morgan Water Supply Scheme (average value with range shown in brackets)

Parameter	Unit	No. 7 Dam Raw Water	Fletcher Creek Raw Water	Mount Morgan WTP Final Water
Nitrate	mg/L	0.15 (<0.01-0.75)	0.16 (<0.01-1.05)	0.14 (0.03-1.7)
Sulphate	mg/L	13.03 (<1-23)	16.11 (7-45)	47.2 (29-73)
Fluoride	mg/L	<0.1 (<0.1-1)	0.11 (<0.1-2.7)	0.2 (<0.1-0.9)
Aluminium (acid-soluble)	mg/L	0.16 (<0.005-0.96)	0.07 (<0.005-0.56)	0.396 (0.015-0.846)
Boron	mg/L	0.06 (0.05-0.06)	0.06 (0.05-0.06)	0.05 (0.05-0.06)
Copper	mg/L	0.002 (0.001-0.019)	0.004 (<0.001-0.006)	0.0063 (<0.001-0.039)
Iron	mg/L	0.51 (<0.05-2.48)	0.207 (<0.01-20)	<0.05 (<0.05-0.08)
Lead	mg/L	<0.001 (<0.001-0.009)	0.001 (<0.001-0.006)	<0.001 (<0.001-0.003)
Manganese	mg/L	0.07 (0.01-0.33)	0.0223 (0.005-5.2)	0.0046 (<0.001-0.047)
Zinc	mg/L	0.023 (<0.005-0.084)	0.028 (<0.005-0.13)	<0.005 (<0.005-0.05)
pH	pH units	8.07 (7.1-8.51)	8.49 (7.0-9.43)	7.81 (7.28-8.41)
Turbidity	NTU	9.21 (1.1-55)	4.91 (0.6-70)	1.34 (0.4-4)
Trihalomethanes	µg/L	NT	NT	106.29 (65-180)
Total Dissolved Solids	mg/L	249 (81-629)	388.54 (140-796)	283.92 (129-854)
Total Alkalinity	mg/L	63.67 (37-88)	172.76 (45-596)	92.88 (38-154)
Chloride	mg/L	21.87 (12-34)	95.76 (19-214)	55.64 (10-135)
Electrical Conductivity	µS/cm	378.35 (130-760)	641.32 (180-1300)	455.12 (236-783)
Calcium	mg/L	22.3 (7.4-48)	33.64 (8.8-120)	21.83 (7-44)
Magnesium	mg/L	15.03 (3.8-37)	28.13 (4.6-60)	14.82 (3.7-34)
Potassium	mg/L	1.39 (<1-2.8)	1 (<1-1.7)	1.36 (<1-2.7)
Sodium	mg/L	28.84 (11-62)	54.94 (16-100)	46.38 (28-66)
Total Hardness	mg/L	117.51 (34-272)	200.82 (41-550)	115.48 (34-250)
True Colour	Pt-Co	37.92 (12-100)	22.4 (2-100)	4.49 (<1-13)
Silica	mg/L	17 (16-18)	24.25 (21-29)	13.8 (13-14)
Arsenic	mg/L	<0.001 (N/A)	<0.001 (N/A)	<0.001 (N/A)
Cadmium	mg/L	<0.001 (<0.0001-0.0003)	<0.0001 (N/A)	<0.0001 (N/A)
Chromium	mg/L	<0.001 (N/A)	<0.001 (N/A)	<0.001 (<0.001-<0.001)
Nickel	mg/L	0.001 (<0.001-0.004)	<0.001 (N/A)	<0.001 (N/A)
Selenium	mg/L	<0.01 (N/A)	<0.01 (N/A)	<0.01 (N/A)
Mercury	mg/L	<0.001 (N/A)	<0.001 (N/A)	<0.001 (N/A)
Total Organic Carbon	mg/L	7.2 (<1-10)	5 (1-13)	3.8 (<1-7)
<i>E. coli</i>	MPN/100ml	NT	NT	<1 (<1-<1)
<i>A. circinalis</i>	cells/ml	ND	NT	NT
<i>C. raciborskii</i>	cells/ml	74 (ND-980)	NT	NT
Cylindrospermopsin	µg/L	NT	NT	NT
<i>Giardia</i> sp.	cysts/10L	<1 (<1-<1)	NT	<1 (<1-<1)
<i>Cryptosporidium</i> sp.	oocysts/10L	<1 (<1-1)	NT	<1 (<1-<1)

Data obtained from sampling events from 2009 and 2013

MPN = most probable number, NTU = nephelometric turbidity units, NT = not tested, ND = nil detected, N/A = not applicable due to insufficient data

Historically, very little data has been obtained for type and number of cyanobacteria in either of the raw water sources. The commencement of regular sampling in early 2011 has detected low levels of the potentially toxic species *Planktolyngbya subtilis*.

The No. 7 Dam raw water quality is influenced by the flow patterns of the Dee River. Flows in the Dee River lead to increases in raw water turbidity and TDS. Installation of on-line turbidity, pH and electrical conductivity meters will provide a better indication of how raw water changes over time. This will enable a better understanding of seasonal or other trends in raw water quality.

Drinking water produced by the MMWTP consistently meets ADWG, however, improvements to the quality of this drinking water are currently being targeted through upgrades and improvements to the operation of the WTP. The installation of on-line analysis of key water quality parameters at different stages throughout the plant will enable improvements to be made in the operation and performance of the WTP. The increased concentration of aluminium and sulphate in the final water compared to the No. 7 Dam raw water reflects the use of aluminium sulphate as the primary coagulant.

The formation of disinfection by-products such as THM throughout the Mount Morgan Water Supply Scheme has been profiled. The highest concentration of THM in the distribution system was 79 µg/L, although a THM concentration of 160 µg/L has previously been measured in the final treated water produced by the MMWTP.

3.3 Drinking Water Quality Incidents

A number of drinking water quality incidents have occurred since the commencement of mandatory reporting of these events in accordance with the *Water Supply (Safety and Reliability) Act*. Table 3.5 contains a description of these events, the nature of the incident and actions taken to manage or resolve the hazard.

Table 3.5: Drinking Water Quality Incidents within the Drinking Water Supply Schemes

Date	Scheme	Incident Type	Location	Action Taken
20 Feb 2009	Rockhampton	<i>E. coli</i> detected	Reticulation	Rechlorination upgraded
27 Aug 2009	Rockhampton	Cyanobacteria	Source water	Normal WTP processes
15 Oct 2009	Rockhampton	<i>E. coli</i> detected	Reticulation	Rechlorination installed
23 Nov 2009	Rockhampton	High chlorine	Reticulation	Rechlorination upgraded
27 Nov 2009	Rockhampton	Cyanobacteria	Final water	WTP processes upgraded
03 Feb 2010	Rockhampton	<i>E. coli</i> detected	Reticulation	Reviewed rechlorination
28 Sep 2010	Rockhampton	<i>E. coli</i> detected	Reticulation	Manual rechlorination started
03 Jan 2011	Mount Morgan	Failed alum dose	WTP	Pump repair, WTP process upgrade commenced
01 Mar 2011	Rockhampton	<i>E. coli</i> detected	Reticulation	Frog-proofed reservoir, Reviewed rechlorination
08 Mar 2011	Rockhampton	<i>E. coli</i> detected	Reticulation	Chlorine residual setpoints increased, Frog-proofed reservoir
15 Feb 2013	Rockhampton	Elevated Manganese	WTP	Reviewed monitoring and treatment options during major flood events.
16 Apr 2013	Rockhampton	<i>E. coli</i> detected	Reticulation	Frog-proofed reservoir. Reviewed rechlorination

All of the *E. coli* detections recorded in the drinking water quality incidents described in Table 3.5 were attributed to green tree frogs gaining access to the inside of service reservoirs at a number of locations across the region.

A range of follow-up actions have been taken to reduce the risk of recurrence of these drinking water quality incidents. More information on these actions and other current or planned projects is provided in the Risk Management Improvement Program below.

3.4 Drinking Water Quality Complaints

Drinking water quality complaints have been received from customers in all three existing drinking water schemes. In most cases these complaints have been due to discoloured water or water containing entrained air bubbles. Table 3.6 shows the number of drinking water quality complaints received during the 2009-2010 reporting year and the 2010-2011 year as at 31 December 2010 for each drinking water scheme.

Table 3.6: Number of Water Quality Complaints for Each Drinking Water Scheme

Period	Rockhampton (per 1000 connections)	Mount Morgan (per 1000 connections)
2009-2010	55 (1.93)	24 (17.4)
2010-2011	85 (2.52)	18 (11.6)
2011-2012	102 (3.42)	16 (10.97)
2012-2013	160 (5.22)	23 (15.6)
2013-2014	54 (1.83)	12 (8.16)

The water quality complaints for the Mount Morgan Water Supply Scheme are typically due to discoloured complaints associated with iron and manganese in the distributed water. Follow up investigations have identified some 'hot-spots' for discoloured water within this scheme.

In Rockhampton the water quality complaints are more evenly spread between discoloured water and other general quality complaints such as taste, odour or appearance. In both schemes, major flood events have led to increased numbers of complaints due to variations in water quality leading to aesthetic changes to the drinking water supplied.

4 HAZARD IDENTIFICATION

The identification of hazards and hazardous events that have the potential to impact water quality is an ongoing process that continues to be conducted by technical, operational and managerial staff within FRW and RRC. See Section 5 below for a more detailed description of the roles of each of the participants in this process.

Table 4.1 contains a list of the specific hazards and hazardous events that have occurred or have the potential to impact water quality across the three drinking water schemes and provides an indication of the frequency of each event. A more detailed assessment of these hazards for each scheme including an assessment of the level of risk with and without existing or proposed controls is provided below in the section on Assessment of Risks.

Table 4.1: Hazards and Hazardous Events That Have or May Impact Drinking Water Quality

Hazards	Hazardous Events	Has Occurred? (Frequency)	Critical Controls
Catchment/Raw Water Storages			
Bacterial Pathogens	Unrestricted livestock	Yes (ongoing)	Monitoring, Multiple barriers
Protozoan Pathogens	Unrestricted livestock	Yes (ongoing)	Monitoring, Multiple barriers
Toxic cyanobacteria	Stratification, eutrophication	Yes (>1/year)	Monitoring, Multiple barriers
Viral Pathogens	Unrestricted livestock	Unknown	Multiple barriers
Toxic/Radioactive metals	Industrial Spill/Release	No	Monitoring, Multiple barriers
Toxic Pesticides/organics	Agriculture	Yes (ongoing)	Monitoring
Perfluorocarbons	Leaching from contaminated lands	Unlikely	Monitoring
High Iron and Manganese	Flow event iron and manganese rich water	Yes (ongoing)	Monitoring, Pre-treatment oxidation
High E.C. or TDS	Industrial Spill/Release; Rising Groundwater; Flood Event	Yes (>1/year)	Monitoring
Excessive Turbidity	Flood Events/Bushfire	No (>1/year)	Monitoring, Multiple barriers
Treatment			
Bacterial Pathogens	Failure of treatment barrier	Yes (<1/year)	Operator training, Operational monitoring and alarms
Protozoan Pathogens	Failure of treatment barrier	No	Operator training, Operational monitoring and alarms
Toxic cyanobacteria	Failure of treatment barrier	Yes (<1/year)	Operator training, Operational monitoring and alarms
Viral Pathogens	Failure of treatment barrier	Unknown	Operator training, Operational monitoring and alarms
Toxic Pesticide/organics	No effective treatment	Yes (ongoing)	Monitoring
High E.C. or TDS	No effective treatment	Yes (>1/year)	Monitoring
Excessive Turbidity	Failure of treatment barrier	Yes (<1/year)	Operator training, Operational monitoring and alarms
Coagulant Underdose	Equipment/process control failure	Yes (<1/year)	Maintenance, Operational monitoring and alarms
Chlorine Underdose	Equipment/process control failure	Yes (<1/year)	Maintenance, Operational monitoring and alarms
Chemical Contamination	Unapproved chemicals	No	Supply contracts, specified QA

Hazards	Hazardous Events	Has Occurred? (Frequency)	Critical Controls
Coagulant Overdose	Equipment/process control failure	No	Operator training, Operational monitoring, Daily chemical usage reporting
Fluoride Overdose	Equipment/process control failure	No	Operator training, Operational monitoring and alarms
Chlorine Overdose	Equipment/process control failure	Yes (<1/year)	Maintenance, Operational monitoring and alarms
Distribution			
Bacterial Pathogens	Animal access to reservoirs	Yes (>1/year)	Inspections/ Operational monitoring and alarms for chlorine residual
Protozoan Pathogens	Animal access to reservoirs	Yes (>1/year)	Inspections/ Operational monitoring and alarms for chlorine residual
Viral Pathogens	Animal access to reservoirs	Yes (>1/year)	Inspections/ Operational monitoring and alarms for chlorine residual
Microbial pathogens	Water mains break	Yes (<1/year)	Mains break repair procedure
Discoloured water	Pipewall biofilm and sediment mobilisation	Yes (>1/year)	Chlorine residual penetration, reticulation air scouring program
No chlorine residual	Long detention time	Yes (ongoing)	Increase chlorination, operate scheme to reduce water age.
Disinfection by-products	High TOC, rechlorination, long detention time	Yes (ongoing)	Effective Treatment/Monitoring
Chemical contamination	Sabotage, terrorism	No	Physical Security/Site Inspection
Excessive chlorination	Equipment/process control failure at rechlorination site	No	Remote monitoring with alarms, Calibration/Site Inspection
Customers Tap			
Contamination	Inappropriate plumbing	No	Compliance inspections
Contamination	Inappropriate use	No	Education Programs

5 ASSESSMENT OF RISKS

Since the preparation of the original risk assessment in the original approved DWQMP (described below) a review has been undertaken to update the risk assessment accordingly based on recent changes in risk profile due to completion of projects identified in the Risk Management Improvement Program or other events. The original risk assessment was prepared in accordance with the AS/NZS:4360 Risk Management Standard through a series of five workshops and meetings involving key FRW management, technical and operational staff working in association with the RRC Risk Management Coordinator. The following personnel attended continue to be involved in the assessment and management of risks to drinking water supplies:

- Jason Plumb (Coordinator Treatment and Supply)
- Ariane Leyden (Water Quality Officer)
- Nimish Chand (Manager FRW)
- Robert Holmes (General Manager Regional Services)

The Coordinator Treatment and Supply and the Coordinator Treatment are responsible for the day-to-day operation of WTPs and other distribution infrastructure. With more than 15 years experience working with water and wastewater the Coordinator Treatment and Supply also has a PhD in microbiology. The Manager FRW and the General Manager Regional Services have extensive experience in Risk Management in the water industry and the Water Quality Officer has more than 5 years experience working with drinking water quality monitoring and has relevant tertiary qualifications.

Appendix A contains the Likelihood and Consequence Ratings tables, the Risk Rating Matrix and an Uncertainty Ratings table that were used in to prepare this Risk Assessment.

This more public health-specific risk assessment is presented in Tables 5.1 to 5.3. These risk assessments provide a description of the key risks that have the potential to impact each drinking water scheme at the catchment, treatment plant and distribution system stages of each scheme, including, some whole of service risks that are more broadly applicable across all schemes. All risks with a Residual Risk Rating above Low are considered unacceptable. In each case Proposed Actions are listed to further mitigate these unacceptable risks. These Proposed Actions are captured in the Risk Management Improvement Program (see Section 12).

Table 5.1: Assessment of Risks with the Potential to Impact Drinking Water Quality in the Rockhampton Water Supply Scheme

Scheme Component	Hazardous Event	Hazard	CR	LH	IRR	Existing Preventative Measure/Barrier	CR	LH	RRR	Uncertainty	Comment/Proposed Further Risk Mitigation	Risk No.
Source, Raw Water Intake	No, low or high flow conditions in Fitzroy Barrage Storage, contamination via discharge release or access e.g. grazing livestock, industry water discharge (unprotected surface water catchment)	Bacterial pathogens	5	5	E25	<ul style="list-style-type: none"> Catchment monitoring and regular inspection of river intake structure for obvious contaminating material Stakeholder engagement towards preventing any high risk activities that might pose a threat. 	3	1	L3	Confident	<ul style="list-style-type: none"> Alarms in place for monitoring of raw water turbidity to alert operator of any significant changes. No apparent change in risk during no, low or high flow events. 	R01
		Protozoan pathogens	5	3	H15	<ul style="list-style-type: none"> Catchment monitoring and regular inspection of river intake structure for obvious contaminating material Stakeholder engagement towards preventing any high risk activities that might pose a threat. 	3	1	L3	Reliable	<ul style="list-style-type: none"> Alarms in place for monitoring of raw water turbidity to alert operator of any significant changes. No Cryptosporidium or Giardia detected in GWTP raw or final water in the last 3 years. No apparent change in risk during no, low or high flow events. 	R02
		Toxic cyanobacteria	5	3	H15	<ul style="list-style-type: none"> Catchment monitoring to detect toxic blooms. Variable depth intake to avoid surface scum during bloom events. Pre-treatment chlorination available to destroy toxic cyanobacteria. Powdered activated carbon dosing if required to remove toxins. 	3	1	L3	Reliable	<ul style="list-style-type: none"> Cyanobacteria season highly dependent on river flow season and origin of flows in the upper catchments. Good engagement with local university to keep up to date with latest local research on cyanobacteria in the catchment. 	R03
		Viral pathogens	5	4	E20	<ul style="list-style-type: none"> Catchment monitoring and regular inspection of river intake structure for obvious contaminating material Stakeholder engagement towards preventing any high risk activities that might pose a threat. 	3	1	L3	Reliable (based on chlorination performance)	<ul style="list-style-type: none"> Alarms in place for monitoring of raw water turbidity to alert operator of any significant changes. No apparent change in risk during no, low or high flow events. 	R04
		Toxic or Radioactive Metals	5	1	M6	<ul style="list-style-type: none"> Catchment monitoring and regular inspection of river intake structure for obvious contaminating material Stakeholder engagement towards preventing any high risk activities that might pose 	3	1	L3	Reliable	<ul style="list-style-type: none"> Constant engagement with other Fitzroy Basin stakeholders about water quality. No metals or radioisotopes detected at concentrations close to ADWG in last 3 years. 	R05

Scheme Component	Hazardous Event	Hazard	CR	LH	IRR	Existing Preventative Measure/Barrier	CR	LH	RRR	Uncertainty	Comment/Proposed Further Risk Mitigation	Risk No.
						a threat. • Pre-treatment oxidation available if required						
		High Iron and Manganese	3	2	M6	• Catchment and raw water monitoring • Pre-treatment oxidation available if required	3	1	L3	Reliable	<ul style="list-style-type: none"> Fitzroy River raw water does not usually contain high iron and manganese. This event only occurs during major flooding events Pre-treatment oxidation is rarely used due to event usually being very short-lived. 	R06
		Toxic Pesticides or Organics	5	1	M6	• Pre-treatment chlorination available to oxidise organics and pesticides if required. • Powdered activated carbon dosing if required to remove soluble compounds	3	1	L3	Reliable	<ul style="list-style-type: none"> Constant discussion with other Fitzroy Basin stakeholders about water quality. No pesticides detected at concentrations close to ADWG in last 3 years. 	R07
		Excessive E.C. or TDS	3	4	H12	• Stakeholder engagement and catchment monitoring. • No additional controls and no effective treatment process	3	3	M9	Confident	<ul style="list-style-type: none"> The combination of natural and artificial inputs of E.C. and sodium has led to the possibility that raw water will become unacceptable quality for treatment using conventional processes. Proposed action: continue to lobby regulator for tighter water quality limits on mine water discharges. 	R08
		Excessive Turbidity	3	2	M6	• On-line analysis of raw water turbidity with alarms in place to alert operator of significant changes in turbidity. • Robust treatment plant and treatment process design. • Stakeholder engagement and upstream monitoring of flow events.	2	1	L2	Confident	<ul style="list-style-type: none"> GWTP capable of 4-log removal of turbidity and can handle raw water >2000 NTU. 	R09
Treatment, Multiple Barriers, Process Control	Failure of Treatment Barrier, Lack of effective treatment, Process control failure	Bacterial pathogens	5	5	E25	<ul style="list-style-type: none"> Coagulation/sedimentation barrier with on-line monitoring of turbidity pre-filtration to assess effectiveness. Filtration performance closely monitored to backwash at >0.2 NTU. Filter to waste valves used for 	3	1	L3	Confident	<ul style="list-style-type: none"> Alarms in place for monitoring of turbidity pre- and post-filtration to ensure process effectiveness. Alarms also in place to ensure effective chlorine residual achieved in clear water reservoirs. Individual filter turbidity rarely above 0.3 NTU. 	R10

Scheme Component	Hazardous Event	Hazard	CR	LH	IRR	Existing Preventative Measure/Barrier	CR	LH	RRR	Uncertainty	Comment/Proposed Further Risk Mitigation	Risk No.
						<ul style="list-style-type: none"> ripening of filters after backwash to ensure turbidity <0.2 NTU. Gas chlorination closely monitored to ensure effective disinfection. 					<ul style="list-style-type: none"> No E. coli detected in GWTP final water in the last 5 years. No difference in performance during no, low or high flow events. 	
		Protozoan pathogens	5	3	H15	<ul style="list-style-type: none"> Coagulation/sedimentation barrier with on-line monitoring of turbidity pre-filtration to assess effectiveness. Filtration performance closely monitored to backwash at >0.2 NTU. Filter to waste valves used for ripening of filters after backwash to ensure turbidity <0.2 NTU. 	3	1	L3	Reliable	<ul style="list-style-type: none"> Alarms in place for monitoring of turbidity pre and post filtration to ensure process effectiveness. Filter to waste valves prevent turbidity spikes following backwash. Individual filter turbidities rarely above 0.3 NTU. No Cryptosporidium or Giardia detected in GWTP raw or final water in the last 3 years. No difference in performance during no, low or high flow events. 	R11
		Toxic cyanobacteria	5	3	H15	<ul style="list-style-type: none"> Coagulation/sedimentation barrier with on-line monitoring of turbidity pre-filtration to assess effectiveness. Pre-coagulation chlorination available to destroy toxic cyanobacteria. Powdered activated carbon dosing if required to remove toxins. 	3	1	L3	Reliable	<ul style="list-style-type: none"> Effective removal of <i>Cylindrospermopsis raciborskii</i> using sedimentation and filtration validated at GWTP. Increased coagulant dose very effective under high bloom conditions. Very little if any penetration of cyanobacteria through to final water during blooms events over the last 3 years. 	R12
		Viral pathogens	5	4	E20	<ul style="list-style-type: none"> Coagulation/sedimentation barrier with on-line monitoring of turbidity pre-filtration to assess effectiveness. Filtration performance closely monitored to backwash at >0.2 NTU. Filter to waste valves used for ripening of filters after backwash to ensure turbidity <0.2 NTU. Gas chlorination closely monitored to ensure effective disinfection. 	4	1	M5	Reliable (based on chlorination performance)	<ul style="list-style-type: none"> Alarms in place for monitoring of turbidity pre- and post-filtration to ensure process effectiveness. Alarms also in place to ensure effective chlorine residual achieved in clear water reservoirs. Individual filter turbidities rarely above 0.3 NTU. No difference in performance during no, low or high flow events. Proposed action: perform testing for viruses for further confirmation of process effectiveness. 	R13
		Toxic or	5	1	M6	<ul style="list-style-type: none"> Coagulation/sedimentation 	3	1	L3	Reliable	<ul style="list-style-type: none"> Constant discussion with other 	R14

Scheme Component	Hazardous Event	Hazard	CR	LH	IRR	Existing Preventative Measure/Barrier	CR	LH	RRR	Uncertainty	Comment/Proposed Further Risk Mitigation	Risk No.
		Radioactive Metals				barrier with on-line monitoring of turbidity pre-filtration to assess effectiveness.					Fitzroy Basin stakeholders about water quality. <ul style="list-style-type: none"> No metals or radioisotopes detected at concentrations close to ADWG in last 3 years. Very effective sedimentation process with 4-log turbidity removal. 	
		Toxic Pesticides or Organics	5	1	M6	<ul style="list-style-type: none"> Pre-coagulation chlorination available to oxidise organics and pesticides if required. Powdered activated carbon dosing if required to remove soluble compounds. 	3	1	L3	Reliable	<ul style="list-style-type: none"> Constant discussion with other Fitzroy Basin stakeholders about water quality. No pesticides detected at concentrations close to ADWG in last 3 years. 	R15
		Excessive E.C. or TDS	3	4	H12	<ul style="list-style-type: none"> Stakeholder engagement and catchment monitoring. No additional controls and no effective treatment process 	3	1	L3	Confident	<ul style="list-style-type: none"> The combination of natural and artificial inputs of E.C. and sodium has led to the possibility that raw water will become unacceptable quality for treatment using conventional processes. 	R16
		Excessive Turbidity	3	2	M6	<ul style="list-style-type: none"> Robust treatment plant and treatment process design. Coagulation/sedimentation barrier with on-line monitoring of turbidity pre-filtration to assess effectiveness. Filtration performance closely monitored to backwash at >0.2 NTU. Filter to waste valves used for ripening of filters after backwash to ensure turbidity <0.2 NTU. 	2	1	L2	Confident	<ul style="list-style-type: none"> GWTP capable of 4-log removal of turbidity and can handle raw water >2000 NTU. In addition, the sedimentation and filtration processes and their controls are reliable and robust. 	R17
	Equipment or Process control failure, Chemical underdosing	Coagulant Underdose	4	3	H12	<ul style="list-style-type: none"> Coagulation/sedimentation barrier with on-line monitoring of turbidity pre-filtration to assess effectiveness. Filtration performance closely monitored to backwash at >0.2 NTU. Duty/Standby dosing pumps available 	2	2	L4	Reliable	<ul style="list-style-type: none"> The on-line turbidity analysis has alarms set to alert operator to any problems with effectiveness of sedimentation process and possible coagulant underdosing. The PACL coagulant is a very effective product and not readily susceptible to underdosing issues 	R18
		Chlorine	5	3	H15	<ul style="list-style-type: none"> Duplicate on-line chlorine 	3	1	L3	Confident	<ul style="list-style-type: none"> The robust design and good 	R19

Scheme Component	Hazardous Event	Hazard	CR	LH	IRR	Existing Preventative Measure/Barrier	CR	LH	RRR	Uncertainty	Comment/Proposed Further Risk Mitigation	Risk No.
		Underdose				<ul style="list-style-type: none"> analysers used to monitor effectiveness of chlorine dosing with low and low low alarms to alert of possible underdosing Duty/Standby chlorinators in place 					performance of the filtration and disinfection systems at the GWTP as well as the relevant SCADA alarms being in place provide good management of this risk	
	Contaminated chemicals, Use of unapproved treatment chemical	Toxic Metals, Toxic Chemicals	5	1	M6	<ul style="list-style-type: none"> Chemical supply contracts in place with stringent quality assurance and chemical analysis specifications required. 	3	1	L3	Reliable	<ul style="list-style-type: none"> Low chemical dose rates and the associated monitoring and daily checking of chemical usage generally prevents any inadvertent overdosing of chemicals that may lead to water quality problems. 	R20
	Equipment or Process control failure, Chemical overdosing	Coagulant Overdose	3	3	M9	<ul style="list-style-type: none"> Trained operators and on-line monitoring of process performance alerts operator of possible overdose Daily reporting of chemical consumption helps operator to identify potential overdosing Verification monitoring used to check for any overdosing of coagulant leading to high aluminium in potable water 	3	1	L3	Confident	<ul style="list-style-type: none"> The PACL coagulant used at GWTP allows for effective treatment at lower aluminium concentrations than alum sulphate helping to avoid any possible impacts from overdosing. Verification monitoring data shows no evidence of any significant overdosing events leading to high aluminium in potable water. 	R21
		Fluoride Overdose	4	2	M8	<ul style="list-style-type: none"> PLC interlocks to shutdown fluoride dosing prior to achieving harmful dose. High concentration alarms to warn operator of potential problem. Redundancy of flow metering and on-line analysis for fluoride. 	3	1	L3	Reliable	<ul style="list-style-type: none"> Fluoride dosing system PLC separate to main WTP PLC and operates independently. High concentration alarms and daily manual testing and instrument calibration help to reduce the risk of any problems associated with high dosing or incorrect fluoride concentration measurements. 	R22
		Chlorine Overdose	4	2	M8	<ul style="list-style-type: none"> PLC interlocks to shutdown chlorine dosing and highlift pump station prior to achieving harmful dose. High concentration alarms to warn operator of potential problem. Redundancy of on-line analysis for chlorine. 	3	1	L3	Confident	<ul style="list-style-type: none"> GWTP high chlorine interlock shuts the WTP highlift pumps down before free chlorine residual exceeds 2.0 mg/L. High concentration alarms and daily manual testing and instrument calibration help to reduce the risk of any problems associated with high dosing or incorrect chlorine concentration measurements. 	R23
Distribution	Contamination	Bacterial	5	3	H15	<ul style="list-style-type: none"> Automated rechlorination or 	3	1	L3	Reliable	<ul style="list-style-type: none"> Automated rechlorination maintains 	R24

Scheme Component	Hazardous Event	Hazard	CR	LH	IRR	Existing Preventative Measure/Barrier	CR	LH	RRR	Uncertainty	Comment/Proposed Further Risk Mitigation	Risk No.
system, trunk infrastructure, reservoirs, reticulation.	due to animals accessing reservoirs.	Pathogens				<ul style="list-style-type: none"> manual rechlorination at most reservoirs. Appropriate roof design to prevent animal access or contaminant entry via roof run-off (except Mt Charlton Reservoir). Regular inspection program to check reservoir integrity and measure free chlorine residual. Reliable rechlorination with alarms to indicate dosing faults. 					<ul style="list-style-type: none"> >0.5 mg/L free chlorine with a setpoint target of 1.0 mg/L. Remote monitoring and low level alarms used to identify and rectify any dosing faults. Standard roof design being specified for all new reservoirs to prevent animal ingress. 	
		Protozoan Pathogens	5	3	H15	<ul style="list-style-type: none"> Appropriate roof design to prevent animal access or contaminant entry via roof run-off. Regular inspection program to check reservoir integrity 	3	1	L3	Reliable	<ul style="list-style-type: none"> Standard roof design being specified for all new reservoirs to prevent animal ingress. 	R25
		Viral Pathogen	5	3	H15	<ul style="list-style-type: none"> Automated rechlorination or manual rechlorination at most main reservoirs. Appropriate roof design to prevent animal access or contaminant entry via roof run-off (except Mt Charlton Reservoir). Regular inspection program, Reliable rechlorination with alarms to indicate dosing faults. 	3	1	L3	Reliable	<ul style="list-style-type: none"> Automated rechlorination maintains >0.5 mg/L free chlorine with a setpoint target of 1.0 mg/L. Remote monitoring and low level alarms used to identify and rectify any dosing faults. Standard roof design being specified for all new reservoirs to prevent animal ingress. 	R26
	Contamination via water mains break or reservoir maintenance activity	Microbial Pathogens	5	4	E20	<ul style="list-style-type: none"> Procedures in place to minimise the entry of contaminating material into broken water mains or reservoirs during reactive or planned maintenance activities. Chlorination and flushing carried out as part of these procedures. 	3	1	L3	Reliable	<ul style="list-style-type: none"> Procedures are based on AWWA methods for chlorination of water mains and reservoirs to ensure effective disinfection. 	R27
	Increased water age,	Excessive disinfection	3	3	M9	<ul style="list-style-type: none"> Effective treatment processes to remove organic carbon, 	3	1	L3	Reliable	<ul style="list-style-type: none"> This hazard is somewhat subject to the prevailing scientific literature or 	R28

Scheme Component	Hazardous Event	Hazard	CR	LH	IRR	Existing Preventative Measure/Barrier	CR	LH	RRR	Uncertainty	Comment/Proposed Further Risk Mitigation	Risk No.
	multiple rechlorination and high total organic carbon	by-products				reticulation monitoring for disinfection by-product formation. <ul style="list-style-type: none"> Use of modelling to manage water age. 					the perception of risk based on health guideline values which vary significantly around the world. <ul style="list-style-type: none"> Efforts are continuing to keep up to date with changes in strategies to prevent or manage disinfection by-product formation. 	
	Increased water age due to long pipelines and lack of nearby rechlorination	No chlorine residual leads to unsafe water	4	4	H16	<ul style="list-style-type: none"> Increased chlorination where required to boost penetration of residual System operation optimised to reduce water age and aid in residual penetration 	3	1	L3	Reliable	<ul style="list-style-type: none"> Most of the reticulation consistently receives water with free chlorine residual >0.2 mg/L, however, this level of protection is not likely to provide an effective barrier against significant quantities of contaminating material. 	R29
	Act of sabotage or terrorism	Toxic agent	5	2	M6	<ul style="list-style-type: none"> Adequate physical security and regular site inspection program. Internal tracking of security keys. Some CCTV at sites with higher risk of unauthorised access. 	4	1	M5	Reliable	<ul style="list-style-type: none"> Signage, physical security and CCTV help to prevent unauthorised access, but are unlikely to be effective against a deliberate act of sabotage or terrorism. Proposed action: identify high risk sites and install CCTV at these sites. 	R30
	Equipment or Process control failure at reservoir rechlorination site	Chlorine Underdose	4	3	H12	<ul style="list-style-type: none"> Remote monitoring using on-line chlorine analysers with low and low low alarms to trigger rectification action Duty/Standby dosing pumps and critical spares kept Regular equipment servicing and regular monitoring and calibration of chlorine on-line analysers. 	3	1	L3	Reliable	<ul style="list-style-type: none"> These measures listed here as well as the focus placed on regular inspection of reservoirs to prevent animal access and contamination provides good management of this risk. 	R31
		Chlorine Overdose	4	2	M8	<ul style="list-style-type: none"> High alarms on chlorine residual concentrations to trigger rectification action, Regular equipment servicing and regular monitoring and calibration of chlorine on-line analysers. 	3	1	L3	Reliable	<ul style="list-style-type: none"> Maintaining a regular inspection and calibration program is an essential part of ensuring that the on-line analysers read correctly and prevent any over-dosing of chlorine. 	R32
Customers Tap	Contamination via backflow or cross connection	Microbial pathogens	5	2	H10	<ul style="list-style-type: none"> Good penetration of free chlorine residual to most parts of the reticulation, Plumbing Inspection team to ensure plumbing and network 	4	1	M5	Reliable	<ul style="list-style-type: none"> Most of the reticulation consistently receives water with free chlorine residual >0.2 mg/L, however, this level of protection is not likely to provide an effective barrier against 	R33

Scheme Component	Hazardous Event	Hazard	CR	LH	IRR	Existing Preventative Measure/Barrier	CR	LH	RRR	Uncertainty	Comment/Proposed Further Risk Mitigation	Risk No.
						assets are constructed to meet legislative and standard requirements.					<p>significant quantities of contaminating material.</p> <ul style="list-style-type: none"> Prevention using backflow prevention devices or good regulation is the preferred approach. Proposed action: create a website Fact Sheet warning of risks of contamination at customer tap 	

Table 5.2: Assessment of Risks with the Potential to Impact Drinking Water Quality in the Mount Morgan Water Supply Scheme

Scheme Component	Hazardous Event	Hazard	CR	LH	IRR	Existing Preventative Measure/Barrier	CR	LH	RRR	Uncertainty	Comment/Proposed Further Risk Mitigation	Risk No.
Source, Raw Water Intake	No, low or high flow conditions in No.7 Dam, contamination via discharge release or access e.g. grazing livestock, (unprotected surface water catchment)	Bacterial pathogens	5	5	E25	<ul style="list-style-type: none"> Catchment for No.7 Dam relatively undisturbed and well forested, however, still technically an unprotected surface water storage Catchment monitoring and on-line raw water turbidity monitoring alerts operator to changes in turbidity. Gas chlorination closely monitored manually to ensure effective disinfection. 	3	1	L3	Reliable	<ul style="list-style-type: none"> Raw water turbidity rarely above 10 NTU throughout periods with no flow in the Dee River. No E. coli detected in WWTP final water in the last 3 years. 	MM01
		Protozoan pathogens	5	3	H15	<ul style="list-style-type: none"> Catchment for No.7 Dam relatively undisturbed and well forested, however, still technically an unprotected surface water storage. Catchment monitoring and on-line raw water turbidity monitoring alerts operator to changes in turbidity. 	3	1	L3	Reliable	<ul style="list-style-type: none"> Raw water turbidity rarely above 10 NTU throughout periods with no flow in the Dee River. No Cryptosporidium or Giardia detected in MMWTP raw or final water in the last 3 years. 	MM02
		Toxic cyanobacteria	5	3	H15	<ul style="list-style-type: none"> Catchment monitoring to detect toxic blooms. Pre-treatment chlorination possible if required to destroy cyanobacteria Some ability to vary the intake depth at No.7 Dam to avoid surface scums. 	3	1	L3	Reliable	<ul style="list-style-type: none"> Cyanobacteria have not posed a significant issue in No. 7 Dam during the last 3 years. Data prior to that is relatively limited. 	MM03
		Viral pathogens	5	4	E20	<ul style="list-style-type: none"> Catchment for No.7 Dam relatively undisturbed and well forested, however, still technically an unprotected surface water storage. Catchment monitoring and on-line raw water turbidity monitoring alerts operator to changes in turbidity. Sedimentation and filtration barriers are generally quite reliable although improved performance is being targeted. 	3	1	L3	Estimate (newly installed on-line monitoring is increasing the level of certainty)	<ul style="list-style-type: none"> Raw water turbidity rarely above 10 NTU throughout periods with no flow in the Dee River. 	MM04

Scheme Component	Hazardous Event	Hazard	CR	LH	IRR	Existing Preventative Measure/Barrier	CR	LH	RRR	Uncertainty	Comment/Proposed Further Risk Mitigation	Risk No.
		Toxic or Radioactive Metals	5	1	M6	<ul style="list-style-type: none"> Catchment for No.7 Dam relatively undisturbed and well forested, however, still technically an unprotected surface water storage. Catchment monitoring program provides indication of changes to raw water quality 	3	1	L3	Reliable	<ul style="list-style-type: none"> No metals or radioisotopes detected at concentrations close to ADWG in last 3 years. 	MM05
		High Iron and Manganese	3	2	M6	<ul style="list-style-type: none"> Catchment monitoring program provides indication of changes to raw water quality Pre-treatment oxidation available if required 	3	1	L3	Reliable	<ul style="list-style-type: none"> Although No. 7 Dam raw water can have periodic increases in levels of iron and manganese, MMWTP potable water has consistently concentrations of iron and manganese beneath ADWG aesthetic guidelines. 	MM06
		Toxic Pesticides or Organics	5	1	M6	<ul style="list-style-type: none"> Catchment for No.7 Dam relatively undisturbed and well forested, however, still technically an unprotected surface water storage. Catchment monitoring program provides indication of changes to raw water quality Pre-treatment chlorination available to oxidise organics and pesticides if required. Powdered activated carbon dosing if required to remove soluble compounds 	3	1	L3	Reliable	<ul style="list-style-type: none"> No pesticides detected at concentrations close to ADWG in last 3 years. 	MM07
		Excessive E.C. or TDS	3	3	M9	<ul style="list-style-type: none"> Catchment monitoring program provides indication of changes to raw water quality Naturally high background E.C. and TDS in raw water means that customers are used to this water quality. 	3	1	L3	Confident	<ul style="list-style-type: none"> Raw water E.C. and TDS average 227 µS/cm and 271 mg/L respectively. 	MM08
		Excessive Turbidity	3	2	M6	<ul style="list-style-type: none"> Catchment monitoring program provides indication of changes to raw water quality On-line monitoring of raw water turbidity with alarms to alert of any large increases in turbidity 	2	1	L2	Reliable	<ul style="list-style-type: none"> Raw water turbidity rarely above 10 NTU throughout periods with no flow in the Dee River. Newly installed on-line monitoring providing a better understanding of raw water turbidity changes during flow and no flow periods. 	MM09
Fletcher Creek	No, low or	High Iron and	3	4	H12	<ul style="list-style-type: none"> Catchment monitoring 	3	1	L3	Estimate	<ul style="list-style-type: none"> With the storage capacity in No.7 	MM10

Scheme Component	Hazardous Event	Hazard	CR	LH	IRR	Existing Preventative Measure/Barrier	CR	LH	RRR	Uncertainty	Comment/Proposed Further Risk Mitigation	Risk No.
Emergency Source, Raw Water Intake (all hazards except for Iron and Manganese as per above for No.7 Dam)	high flow conditions in No.7 Dam, contamination via discharge release or access e.g. grazing livestock, (unprotected surface water catchment)	Manganese				<ul style="list-style-type: none"> program provides indication of current raw water quality Source water only used in an emergency which is very unlikely Pre-treatment oxidation available to assist with iron and manganese removal 					<ul style="list-style-type: none"> much greater than in previous years when Fletcher Creek was more commonly used, it is unlikely that this water source will be used again. Nevertheless monitoring and infrastructure maintenance continues should the need arise to use this water source. 	
Treatment, Multiple Barriers, Process Control	Failure of Treatment Barrier, Lack of effective treatment, Process control failure	Bacterial pathogens	5	5	E25	<ul style="list-style-type: none"> Coagulation/sedimentation and filtration barriers reasonably reliable and effective. Gas chlorination closely monitored manually to ensure effective disinfection. 	3	1	L3	Reliable	<ul style="list-style-type: none"> Alarms in place for monitoring of turbidity post-filtration to ensure process effectiveness. No E. coli detected in MMWTP final water in the last 3 years. 	MM11
		Protozoan pathogens	5	3	H15	<ul style="list-style-type: none"> Coagulation/sedimentation and filtration barriers reasonably reliable and effective. Newly installed on-line analysis of filtered water turbidity with alarms in place to alert operator of poor performance. 	4	2	M8	Reliable	<ul style="list-style-type: none"> Alarms in place for monitoring of turbidity post filtration to help optimise sedimentation and filtration performance. No Cryptosporidium or Giardia detected in MMWTP raw or final water in the last 3 years. Further optimise filter performance or look at installing UV disinfection if required. 	MM12
		Toxic cyanobacteria	5	3	H15	<ul style="list-style-type: none"> Coagulation/sedimentation and filtration barriers reasonably reliable and effective. Newly installed on-line analysis of filtered water turbidity with alarms in place to alert operator of poor performance. Pre-coagulation chlorination available if required to destroy toxic cyanobacteria. Powdered activated carbon dosing if required to remove toxins. 	4	2	M8	Reliable	<ul style="list-style-type: none"> Proposed action: conduct more analysis to determine effectiveness of each treatment barrier for removal of cyanobacteria 	MM13

Scheme Component	Hazardous Event	Hazard	CR	LH	IRR	Existing Preventative Measure/Barrier	CR	LH	RRR	Uncertainty	Comment/Proposed Further Risk Mitigation	Risk No.
		Viral pathogens	5	4	E20	<ul style="list-style-type: none"> Coagulation/sedimentation and filtration barriers reasonably reliable and effective. Newly installed on-line analysis of filtered water turbidity with alarms in place to alert operator of poor performance. Automated gas chlorination to ensure effective disinfection. 	4	2	M8	Reliable	<ul style="list-style-type: none"> Alarms in place for monitoring of turbidity post-filtration to ensure process effectiveness. Proposed action: perform testing for viruses for further confirmation of process effectiveness. 	MM14
		Toxic or Radioactive Metals	5	1	M6	<ul style="list-style-type: none"> Coagulation/sedimentation and filtration barriers reasonably reliable and effective. Catchment for No.7 Dam relatively undisturbed and well forested, however, still technically an unprotected surface water storage. 	3	1	L3	Reliable	<ul style="list-style-type: none"> No metals or radioisotopes detected at concentrations close to ADWG in last 3 years. 	MM15
		Toxic Pesticides or Organics	5	1	M6	<ul style="list-style-type: none"> Pre-coagulation chlorination available to oxidise organics and pesticides if required. Powdered activated carbon dosing if required to remove soluble compounds. Catchment for No.7 Dam relatively undisturbed and well forested, however, still technically an unprotected surface water storage. 	3	1	L3	Reliable	<ul style="list-style-type: none"> No pesticides detected at concentrations close to ADWG in last 3 years. 	MM16
		Excessive E.C. or TDS	3	2	M6	<ul style="list-style-type: none"> On-line monitoring of raw water and final water E.C. used to alert operator of changes to water quality. 	3	1	L3	Estimate (newly installed on-line monitoring is increasing the level of certainty)	<ul style="list-style-type: none"> Customers are historically adapted to periods of potable water having elevated E.C. and TDS. There does not appear to be any need to further reduce this risk. 	MM17
		Excessive Turbidity	4	2	M8	<ul style="list-style-type: none"> Coagulation/sedimentation and filtration barriers reasonably reliable and effective. On-line water quality analysis of raw and filtered water 	4	1	M5	Reliable	<ul style="list-style-type: none"> On-line monitoring of filtration performance and filtered water turbidity with alarms to alert operator or any reduced performance Proposed action: continue to 	MM18

Scheme Component	Hazardous Event	Hazard	CR	LH	IRR	Existing Preventative Measure/Barrier	CR	LH	RRR	Uncertainty	Comment/Proposed Further Risk Mitigation	Risk No.
						provides operational monitoring of barrier effectiveness					use newly installed on-line analysis to drive further process optimisation	
	Process failure leads to sludge return to inlet of WTP from sludge lagoons	Excessive Turbidity	4	2	M8	<ul style="list-style-type: none"> Return of supernatant from sludge lagoons is a fully manual process that is monitored visually to prevent sludge draw-off Automated process interlocked with WTP operation very low flow only 	3	1	L3	Reliable	<ul style="list-style-type: none"> Manual process reliable but further risk mitigation possible. 	MM19
	Equipment or Process control failure, Chemical underdosing	Coagulant Underdose	4	3	H12	<ul style="list-style-type: none"> On-line water quality analysis of raw and filtered water provides operational monitoring of barrier effectiveness Duty/Standby dosing pumps available 	3	2	M6	Reliable	<ul style="list-style-type: none"> The on-line turbidity analysis has alarms set to alert operator to any problems with effectiveness of sedimentation process and possible coagulant underdosing. Proposed action: convert coagulant dosing to liquid alum to allow for on-line flow metering and better measurement of chemical usage. 	MM20
		Chlorine Underdose	5	3	H15	<ul style="list-style-type: none"> Automated gas chlorination installed with good on-line monitoring and control Alarms generated if chlorine dosing problem with remote monitoring of system to detect any issues. 	3	1	L3	Reliable	<ul style="list-style-type: none"> System highly effective with chlorine residual typically between 1 and 1.5 mg/L with a long contact time in the clear water reservoir. 	MM21
	Contaminated chemicals, Use of unapproved treatment chemical	Toxic Metals, Toxic Chemicals	5	1	M6	<ul style="list-style-type: none"> Chemical supply contracts in place with stringent quality assurance and chemical analysis specifications required. 	3	1	L3	Reliable	<ul style="list-style-type: none"> Verification monitoring data shows no evidence of any overdosing events leading to reduce quality potable water. 	MM22
	Equipment or Process control failure, Chemical overdosing	Coagulant Overdose	3	3	M9	<ul style="list-style-type: none"> Trained operators and on-line monitoring of process parameters such as pH alerts operator to possible overdose Daily reporting of chemical consumption helps operator to identify potential overdosing Verification monitoring used to check for any overdosing of coagulant leading to high 	3	1	L3	Confident	<ul style="list-style-type: none"> Verification monitoring data shows no evidence of any significant overdosing events leading to high aluminium in potable water. 	MM23

Scheme Component	Hazardous Event	Hazard	CR	LH	IRR	Existing Preventative Measure/Barrier	CR	LH	RRR	Uncertainty	Comment/Proposed Further Risk Mitigation	Risk No.
						aluminium in potable water						
		Fluoride Overdose	4	2	M8	<ul style="list-style-type: none"> PLC interlocks to shutdown fluoride dosing prior to achieving harmful dose. High concentration alarms to warn operator of potential problem. Redundancy of flow metering and on-line analysis for fluoride. 	3	1	L3	Reliable	<ul style="list-style-type: none"> Fluoride dosing system PLC separate to main WTP PLC and operates independently. High concentration alarms and daily manual testing and instrument calibration help to reduce the risk of any problems associated with high dosing or incorrect fluoride concentration measurements. 	MM24
		Chlorine Overdose	4	2	M8	<ul style="list-style-type: none"> Automated gas chlorination installed with good on-line monitoring and control Alarms generated if chlorine dosing problem with remote monitoring of system to detect any issues. 	3	1	L3	Reliable	<ul style="list-style-type: none"> System highly effective with chlorine residual typically between 1 and 1.5 mg/L with a long contact time in the clear water reservoir. 	MM25
Distribution system, trunk infrastructure, reservoirs, reticulation.	Contamination due to animals accessing reservoirs.	Bacterial Pathogens	5	3	H15	<ul style="list-style-type: none"> Automatic rechlorination at only other reservoirs as required. Appropriate roof design to prevent animal access or contaminant entry via roof run-off. Regular inspection program to check reservoir integrity and measure free chlorine residual. 	3	1	L3	Reliable	<ul style="list-style-type: none"> Standard roof design being specified for all new reservoirs to prevent animal ingress. Regular manual testing of free chlorine residual to determine if manual chlorination is effective but further action is being taken to further mitigate risk. 	MM26
		Protozoan Pathogens	5	3	H15	<ul style="list-style-type: none"> Appropriate roof design to prevent animal access or contaminant entry via roof run-off. Regular inspection program to check reservoir integrity 	3	1	L3	Estimate	<ul style="list-style-type: none"> Standard roof design being specified for all new reservoirs to prevent animal ingress. 	MM27
		Viral Pathogen	5	3	H15	<ul style="list-style-type: none"> Automatic rechlorination with on-line monitoring. Appropriate roof design to prevent animal access or contaminant entry via roof run-off. Regular inspection program to check reservoir integrity and measure free chlorine 	3	1	L3	Estimate	<ul style="list-style-type: none"> Standard roof design being specified for all new reservoirs to prevent animal ingress. Regular manual testing of free chlorine residual to determine if manual chlorination is effective but further action is being taken to further mitigate risk. 	MM28

Scheme Component	Hazardous Event	Hazard	CR	LH	IRR	Existing Preventative Measure/Barrier	CR	LH	RRR	Uncertainty	Comment/Proposed Further Risk Mitigation	Risk No.
						residual.						
	Contamination via water mains break or reservoir maintenance activity	Microbial Pathogens	5	4	E20	<ul style="list-style-type: none"> Procedures in place to minimise the entry of contaminating material into broken water mains or reservoirs during reactive or planned maintenance activities. Chlorination and flushing carried out as part of these procedures. 	3	1	L3	Reliable	<ul style="list-style-type: none"> Procedures are based on AWWA methods for chlorination of water mains and reservoirs to ensure effective disinfection. 	MM29
	Increased water age, multiple rechlorination and high total organic carbon	Excessive disinfection by-products	3	3	M9	<ul style="list-style-type: none"> Effective treatment processes to remove organic carbon, reticulation monitoring for disinfection by-product formation. Use of modelling to manage water age. 	3	1	L3	Reliable	<ul style="list-style-type: none"> This hazard is somewhat subject to the prevailing scientific literature or the perception of risk based on health guideline values which vary significantly around the world. Efforts are continuing to keep up to date with changes in strategies to prevent or manage disinfection by-product formation. 	MM30
	Increased water age due to long pipelines and lack of nearby rechlorination	No chlorine residual leads to unsafe water	4	4	H16	<ul style="list-style-type: none"> Increased chlorination where required to boost penetration of residual System operation optimised to reduce water age and aid in residual penetration 	3	1	L3	Reliable	<ul style="list-style-type: none"> Most of the reticulation consistently receives water with free chlorine residual >0.2 mg/L, however, this level of protection is not likely to provide an effective barrier against significant quantities of contaminating material. 	MM31
	Act of sabotage or terrorism	Toxic agent	5	2	M6	<ul style="list-style-type: none"> Adequate physical security and regular site inspection program. Internal tracking of security keys. 	4	1	M5	Reliable	<ul style="list-style-type: none"> Signage, physical security and CCTV help to prevent unauthorised access, but are unlikely to be effective against a deliberate act of sabotage or terrorism. Proposed action: identify high risk sites and install CCTV at these sites. 	MM32
	Equipment or Process control failure at reservoir rechlorination site	Chlorine Underdose	4	3	H12	<ul style="list-style-type: none"> Automatic rechlorination at only other reservoir as required. Underdose is currently dependent on regular inspection and chlorine testing program 	3	1	L3	Reliable	<ul style="list-style-type: none"> Regular manual testing of free chlorine residual to determine if chlorination is effective but further action is being taken to further mitigate risk. 	MM33
		Chlorine Overdose	4	2	M8	<ul style="list-style-type: none"> Manual rechlorination at only other reservoir as required. 	3	1	L3	Reliable	<ul style="list-style-type: none"> Regular manual testing of free chlorine residual to determine if 	MM34

Scheme Component	Hazardous Event	Hazard	CR	LH	IRR	Existing Preventative Measure/Barrier	CR	LH	RRR	Uncertainty	Comment/Proposed Further Risk Mitigation	Risk No.
						<ul style="list-style-type: none"> Overdosing is almost impossible given current practice of manual rechlorination, although instructions followed to determine hypochlorite tablet dose added. 					chlorination is effective but further action is being taken to further mitigate risk.	
	Mobilisation of Pipewall Biofilm or Sediments	Discoloured Water	3	4	H12	<ul style="list-style-type: none"> Increased free chlorine residual penetration through distribution system Air scouring program to clear reticulation 'hot spots' 	2	2	L4	Reliable	<ul style="list-style-type: none"> The air scouring program has been shown to be effective where applied to date. This work will continue as required. 	MM35
Customers Tap	Contamination via backflow or cross connection	Microbial pathogens	5	2	H10	<ul style="list-style-type: none"> Good penetration of free chlorine residual to most parts of the reticulation, Plumbing Inspection team to ensure plumbing and network assets are constructed to meet legislative and standard requirements. 	5	1	M6	Reliable	<ul style="list-style-type: none"> Most of the reticulation consistently receives water with free chlorine residual >0.2 mg/L, however, this level of protection is not likely to provide an effective barrier against significant quantities of contaminating material. Prevention using backflow prevention devices or good regulation is the preferred approach. Proposed action: create a website Fact Sheet warning of risks of contamination at customer tap 	MM36

Table 5.3: Assessment of Whole of Service Risks with the Potential to Impact Drinking Water Quality in Each Drinking Water Scheme

Scheme Component	Hazardous Event	Hazard	CR	LH	IRR	Existing Preventative Measure/Barrier	CR	LH	RRR	Uncertainty	Comment/Proposed Further Risk Mitigation	Risk No.
Whole of Service	Extended Loss of Power to Infrastructure	No chlorine dosing at Reservoir Rechlorination Sites	4	3	H12	<ul style="list-style-type: none"> Hypochlorite kept in stock for manual dosing if required Portable pumping systems able to be used to pump hypochlorite 	3	1	L3	Reliable	<ul style="list-style-type: none"> In an extended power outage scenario, mobile gensets would be used if required to assist with operation of rechlorination sites 	W01
		Inability to Treat Water to Potable Standard	4	3	H12	<ul style="list-style-type: none"> Soon to be Emergency Genset at GWTP. Significant storage in reservoirs for emergency supplies for a short period 	3	1	L3	Reliable	<ul style="list-style-type: none"> In a power outage all electrical systems would stop including pumps which means that untreated water would not enter distribution system 	W02
	Loss of Radio Telemetry	Unsafe exceedances not detected	4	3	H12	<ul style="list-style-type: none"> Rapid response to reinstate radio telemetry or other communications links as soon as possible Most critical systems have localised control to avoid failure during communications outage Critical spares kept for all communications systems 	3	1	L3	Reliable	<ul style="list-style-type: none"> Highly trained competent staff available internally to attend to communications faults 	W03
	Lack of qualified and competent staff	Poor decision making and low competency leads to unsafe practices	4	3	H12	<ul style="list-style-type: none"> Training provided as appropriate to operations and maintenance staff Exposure of staff to industry events and technical developments 	3	1	L3	Reliable	<ul style="list-style-type: none"> Attracting suitably qualified staff during the mining boom will always prove to be somewhat of a challenge 	W04
	Lack of availability of chemical supplies	Critical chemical processes cease leading to unsafe water	4	3	H12	<ul style="list-style-type: none"> Backup stocks and additional storage of critical treatment chemicals Alarms on most storage vessels to indicate when they need to be restocked Good chemical supply contracts 	3	1	L3	Reliable	<ul style="list-style-type: none"> Regular checking of chemical inventories done to ensure chemical availability. 	W05
	No information management system	Loss of important information	4	3	H12	<ul style="list-style-type: none"> Manual document system in place Electronic archiving in use 					<ul style="list-style-type: none"> Continuous improvement is undertaken through revision of critical information 	W06

6 MANAGING RISKS

The assessment of risks for each drinking water scheme and the whole of service risks outlined above also provide a description of the existing risk treatments that minimise the risk posed by each hazard or hazardous event. The existing risk treatments include (but are not limited to), Operation and Maintenance (O&M) Manuals and procedures, water quality monitoring programs, preventative maintenance programs, redundancy in design, critical spares inventory, chemical supply contracts, physical security, inspection programs, staff training and awareness, on-line monitoring and SCADA alarming, multiple treatment barriers, stakeholder engagement and asset management planning. These risk treatments are described in more detail in the following sections of the DWQMP. A number of risks continue to have an unacceptable albeit only moderate Residual Risk Rating. These risks and the proposed additional treatments are described in Table 6.1.

6.1 Unacceptable Risks to Drinking Water Quality

Of the 69 individual risks that were rated 11 of the risks were considered to be unacceptable levels of risk as they have a moderate Residual Risk Rating (see Table 6.1). Proposed Actions have been identified to further mitigate each risk. The Proposed Actions being taken to mitigate these unacceptable risks form part of the Risk Management Improvement Program (see Section 12).

Table 6.1: Unacceptable Risks Identified from Risk Assessments and Proposed Treatments

Risk No.	Component-Event-Hazard	RRR	Proposed Action
Rockhampton Water Supply Scheme			
R08	Source – Contamination of raw water Excessive E.C. or TDS	M9	Continue to lobby regulator for tighter water quality limits on mine water discharges.
R13	Treatment – Lack of effective treatment Viral Pathogens	M5	Perform testing for viruses for further confirmation of process effectiveness.
R30	Distribution – Sabotage or Terrorism Toxic agent	M5	Identify high risk sites and install CCTV at these sites.
R33	Customers Tap – Contamination Microbial Pathogens	M5	Create a website Fact Sheet warning of risks of contamination at customer tap
Mount Morgan Water Supply Scheme			
MM12	Treatment – Lack of effective treatment Protozoan Pathogens	M8	Use newly installed on-line analysis to drive further process optimisation.
MM13	Treatment – Lack of effective treatment Toxic Cyanobacteria	M8	Use newly installed on-line analysis to drive further process optimisation. Conduct more analysis to determine effectiveness of each treatment barrier for removal of cyanobacteria.
MM14	Treatment – Lack of effective treatment Viral Pathogens	M8	Perform testing for viruses for further confirmation of process effectiveness.
MM18	Treatment – Lack of effective treatment Excessive Turbidity	M5	Use newly installed on-line analysis to drive further process optimisation.
MM20	Treatment – Process control failure Coagulant Underdose	M6	Convert coagulant dosing to liquid alum to allow for on-line flow metering and better measurement of chemical usage.
MM32	Distribution – Sabotage or Terrorism Toxic agent	M5	Identify high risk sites and install CCTV at these sites.
MM36	Customers Tap – Contamination Microbial Pathogens	M6	Create a website Fact Sheet warning of risks of contamination at customer tap

7 OPERATION AND MAINTENANCE PROCEDURES

7.1 Manuals and Procedures for Drinking Water Schemes

Operation and Maintenance (O&M) Manuals exist for all WTP and many of their unit processes (e.g. chemical dosing systems) although most of these are not fully up to date due to changes since amalgamation. Table 7.1 contains a list of relevant manuals and procedures, the date they were prepared, the date for their next revision (if applicable) and the responsible officer. FRW is currently in the process of reviewing and renewing all WTP manuals and converting them into a standard O&M format (WTP template document released by the Queensland Water Directorate (QWD)) to allow for consistency of process description and to facilitate the ongoing updating of these manuals as changes are made to infrastructure or operating procedures. Once updated in electronic form manuals will be added to the Honeywell Experion SCADA system with active links to the manuals via the click of a button on the relevant SCADA screens.

Table 7.1: Operation and Maintenance Manuals and Relevant Procedures for Managing Drinking Water Infrastructure

Document	Date Prepared	Last Reviewed	Date For Revision	Responsible Officer
Fitzroy Basin Resource Operations Plan	2006	N/A	2011	N/A
Glenmore WTP O&M Manual (QWD template)	In preparation	N/A	Ongoing, part of WTP Upgrade	Coordinator Treatment and Supply
Mount Morgan WTP O&M Manual (Original)	1993	1993	Not planned	Coordinator Treatment and Supply
Mount Morgan WTP O&M Manual (QWD template)	In preparation	N/A	Ongoing, part of WTP Upgrade	Coordinator Treatment and Supply
Rockhampton to Yeppoon Pipeline O&M Manual	2010	2010	Not planned	Coordinator Treatment and Supply
Lucas St Reservoir, Pump Station O&M Manual	2003	2003	Not planned	M&E Services Engineer
Rechlorination O&M Manual	In preparation	In progress	Ongoing as part of Upgrades	M&E Services Engineer
Glenmore WTP Fluoridation O&M Manual	2010	2010	Not planned	M&E Services Engineer
Mount Morgan WTP Fluoridation O&M Manual	2011	2011	Not planned	M&E Services Engineer
Activated Carbon Loading Procedure	2010	2010	As required	Coordinator Treatment and Supply
Mains Break Repair Procedure	Unknown	In progress	As required	Coordinator Network Services
Reservoir Disinfection and Inspection Procedure	Unknown	In progress	As required	Coordinator Treatment and Supply
Water Mains Air-Scouring Procedure	2010	In progress	As required	Coordinator Network Services
Cyanobacteria Monitoring and Management Procedure	2009	2014	As required	Coordinator Treatment and Supply

N/A = not applicable

Standard operating procedures are used for the operation of unit processes or associated equipment (e.g. powdered activated carbon bulk bag unloading system) to ensure that are operated according to manufacturer’s specifications. Similarly, procedures for the operation and calibration of on-line and bench top analytical instrumentation are also in place. In most cases these procedures are as supplied by the manufacturer but in some instances the procedures are reproduced in a format that allows co-location next to the equipment being operated to help ensure correct operation occurs. Procedures are also in place for the disinfection of reservoirs, new water mains and broken water mains and for the regular reservoir inspection program and reticulation network air-scouring. Often these procedures are prepared in checklist format to document the completion of tasks for archiving purposes. FRW is currently reviewing and allocating numbers to all procedures to ensure that a register of current procedures is kept up to date.

The WTP O&M Manuals listed in Table 7.1 form the basis of the operating parameters coded into PLC codes or SCADA control setpoints used to control key all key process treatment steps. The reviewing of these manuals is being done to ensure that there is consistency of information between the manuals and all the current operational settings used in PLC programs and SCADA settings. Since amalgamation, a large amount of capital upgrade work has been completed in all schemes and work is currently underway to ensure that all these infrastructure changes are captured in the relevant O&M manuals and procedures.

7.2 Preventative Maintenance Program

A preventative maintenance program is currently in place for drinking infrastructure within each supply scheme. The Conquest asset and maintenance management system is used to manage planned and reactive maintenance activities. More than 130 planned maintenance tasks are conducted by FRW staff to ensure the continued reliable operation of a range of mechanical, electrical and process control system components. Table 7.2 provides an overview summary of the main types of preventative maintenance activities that are conducted and their frequency.

Table 7.2: Overview of Preventative Maintenance Program for Drinking Water Infrastructure

Equipment Category	Specific Task	Frequency
Electrical	Backup generator servicing	yearly
	Switchboard thermography testing	yearly
	Chlorine gas sensor testing and servicing	monthly
	Uninterruptible Power Supply servicing	6 monthly
Mechanical	WPS pump servicing and greasing	3 monthly
	WTP Air compressor and blower servicing	3 monthly
	WTP coagulant dose pump servicing	3 monthly
	Chlorinator and vacuum regulator servicing	6 monthly
	Low lift and High lift pump hydraulic oil checking	3 monthly
	Low lift pump intake screen cleaning	2 weekly
Process Control	pH, Electrical conductivity and turbidity meter calibrations	monthly
	Chlorine analysers servicing	yearly
	Chlorine analysers calibration	weekly
Reservoirs	Site, security and animal ingress inspection	monthly

7.3 Reactive Maintenance Management

All reactive maintenance requirements are managed using a standard approach. Upon discovery of a process or component fault or an excursion from normal operational performance, a maintenance request is raised using the Conquest software system by the WTP Operator or staff member who discovers the issue. The nature and location of the issue is described in the request together with an indication of the urgency of the maintenance request. This request is then circulated automatically to key supervisors and managers involved in the operation and maintenance of drinking water infrastructure to provide the opportunity for comment on the fault or its urgency rating to optimise the prioritisation of reactive maintenance activities. At the same time a reactive maintenance worker is dispatched to attend and rectify the issue. Reporting of the progress made against the reactive maintenance targets is conducted to ensure tasks are completed in a timely manner.

8 MANAGEMENT OF EMERGENCIES, INCIDENTS, OR EXCURSIONS FROM NORMAL PERFORMANCE

8.1 Emergency Response Plan

FRW has in place an Emergency Response Plan (ERP) that details the approach for managing the response to, and recovery from, emergency situations e.g. natural disasters. The ERP has recently been reviewed and updated following the prolonged major flooding event that occurred during the 2010-2011 summer season. Mock emergency scenarios and desktop exercise alert workshops are held to provide training to key staff involved in the management of emergency situations.

8.2 Managing Drinking Water Incidents or Excursions from Normal Operational Performance

Drinking water incidents including reportable drinking water quality incidents or excursions from normal operational performance are rated and managed using the information provided Table 8.1 and Figure 8.1. An additional flow charted procedure is in place for the management of microbiological water quality incidents following the detection of non-compliances within the drinking water schemes. Table 8.1 also provides information about the response and rectification time targets to return to normal safe operating status.

Members of the Treatment and Supply team within FRW together with other key stakeholders play different roles in the management of drinking water quality incidents or any excursion from normal operational performance. For example an excursion from normal operating range is usually identified by a Treatment Plant Operator through a SCADA alarm whereas a non-compliance detected through verification monitoring (e.g. *E. coli* detection) is normally identified by the Water Quality Officer or Coordinator Treatment and Supply through the receipt of a non-compliant test result from an external laboratory. Depending on the nature of the excursion or non-compliance, each of these team members will attempt to take any action possible to immediately resolve the matter or alternatively, a reactive maintenance action request will be submitted electronically for dispatch to maintenance staff according to the Priority Ratings given in Table 8.1.

The Maintenance Planner and Supervisor Operations are responsible for confirming the Priority Rating and dispatching the reactive request to the maintenance staff. This tasking is currently done using the Conquest maintenance management software. In either case, the matter will be reported immediately to either the Water Quality Officer or Coordinator Treatment and Supply. These three officers are responsible for assessing any action taken or for formulating a plan of further action (e.g. resampling) if required to address or investigate the non-compliance and for directing staff to complete these actions.

Table 8.1: Priority Ratings of Possible Drinking Water Incidents or Events and the associated Response and Rectification Time Targets

Consequences (always rate using consequence with greatest potential impact)			
Generic Description	Negative public perception Prevention of normal operations Increased reactive maintenance Disruption to normal staff duties Loss of critical spares or supplies	Public complaint or environmental spill Reduction in service level Loss of normal design operating status Loss of preventative maintenance Unacceptable civil or site condition	Possible public health impact Loss of service or non-compliance Loss of SCADA control or monitoring Loss of whole treatment barrier Security or structural breach
<i>Examples</i>	<i>Site left untidy or poorly signed Process shutdown required Increased need for fault resetting Normal planned tasks disrupted No spare parts or store chemicals</i>	<i>Widespread drinking water complaint Significant drop in reticulation pressure Low or high alarm, loss of duty standby On-line instrumentation not calibrated Reservoir roof structure damaged</i>	<i>Reservoir contamination detected Exceedance of ADWG health value No radio telemetry or local comms Chlorine dosing failure Unauthorised access to WTP</i>
Likelihood			
Within 1 to 7 days	P2 – Moderate Impact/Risk	P1 – High Impact/Risk	P1 – High Impact/Risk
Within 7 to 28 days	P3 – Low Impact/Risk	P2 – Moderate Impact/Risk	P1 – High Impact/Risk
Not within 28 days	P3 – Low Impact/Risk	P3 – Low Impact/Risk	P2 – Moderate Impact/Risk
Response and Rectification Time Targets			
Priority Rating	Response Time to Site	Rectification Time	Maximum Tolerable Outage
P1	1 hour	5 hour	5 hour
P2	2 hours	24 hours	24 hours
P3	24 hours	5 days	5 days

In the event of a notifiable water quality incident, the incident will be reported to the Office of the Water Supply Regulator and simultaneously to Queensland Health and then investigated by either the Coordinator Water Quality or the Manager Treatment and Supply. Upon completion of the investigation the incidents are reported in writing to the Office of the Water Supply Regulator and to Queensland Health. Once fully resolved, the incident reporting is completed and any long term actions or preventative measures are incorporated into O&M Manuals or procedures or incorporated into future Capital Works Programs in order to prevent further incidents or excursions from normal operational performance targets.

Examples of specific actions that may be taken for events with different ratings are:

P1 Rating

- Resampling for further chemical or microbiological testing
- Manual dosing of sodium hypochlorite to boost disinfection
- Draining reservoirs or issuing boil water alerts to avoid impact on public health
- sourcing water from alternative supplies
- Install critical spare for chemical dosing pump

P2 Rating

- flushing of mains to clear a discoloured water event,
- changes made to treatment chemical dosing rates (e.g. coagulant dose),
- process control settings (e.g. changes to PID loops on chlorination systems)

P3 Rating

- air-scouring of water mains to remove sediment or biofilm

8.3 Emergency Contact Information

Table 8.2 identifies key personnel or stakeholders involved in managing drinking water incidents including FRW staff and officers within the Office of the Water Supply Regulator and Queensland Health. The positions in bold have in-depth knowledge of water treatment processes and/or water quality biology and chemistry and will engage with State Government officers if required to manage drinking water quality incidents.

Table 8.2: FRW or other Personnel Involved in Managing Drinking Water Incidents

Name	Position	Role	Phone Numbers
Nimish Chand	Manager FRW	Overall FRW Responsibility	1300 22 55 77
Jason Plumb	Coordinator Treatment & Supply	Reporting, Investigating, Managing Responses	1300 22 55 77
Ariane Leyden	Water Quality Officer	Sampling, Reporting	1300 22 55 77
Dean Kreiser	M&E Services Engineer	Rectification Actions	1300 22 55 77
Fredrich Ramirez	Coordinator Maintenance Planning	Rectification Actions	1300 22 55 77
Jeff Schneider	Supervisor Operations	Rectification Actions	1300 22 55 77
Office of the Water Supply Regulator	Regulator for Drinking Water	Regulator, Management of Incident Response	1300 59 67 09
Queensland Health	Regulator for Public Health	Management of Incident Response	4920 6895

Figure 8.1: Flow Chart Showing Approach to Drinking Water Incident Management

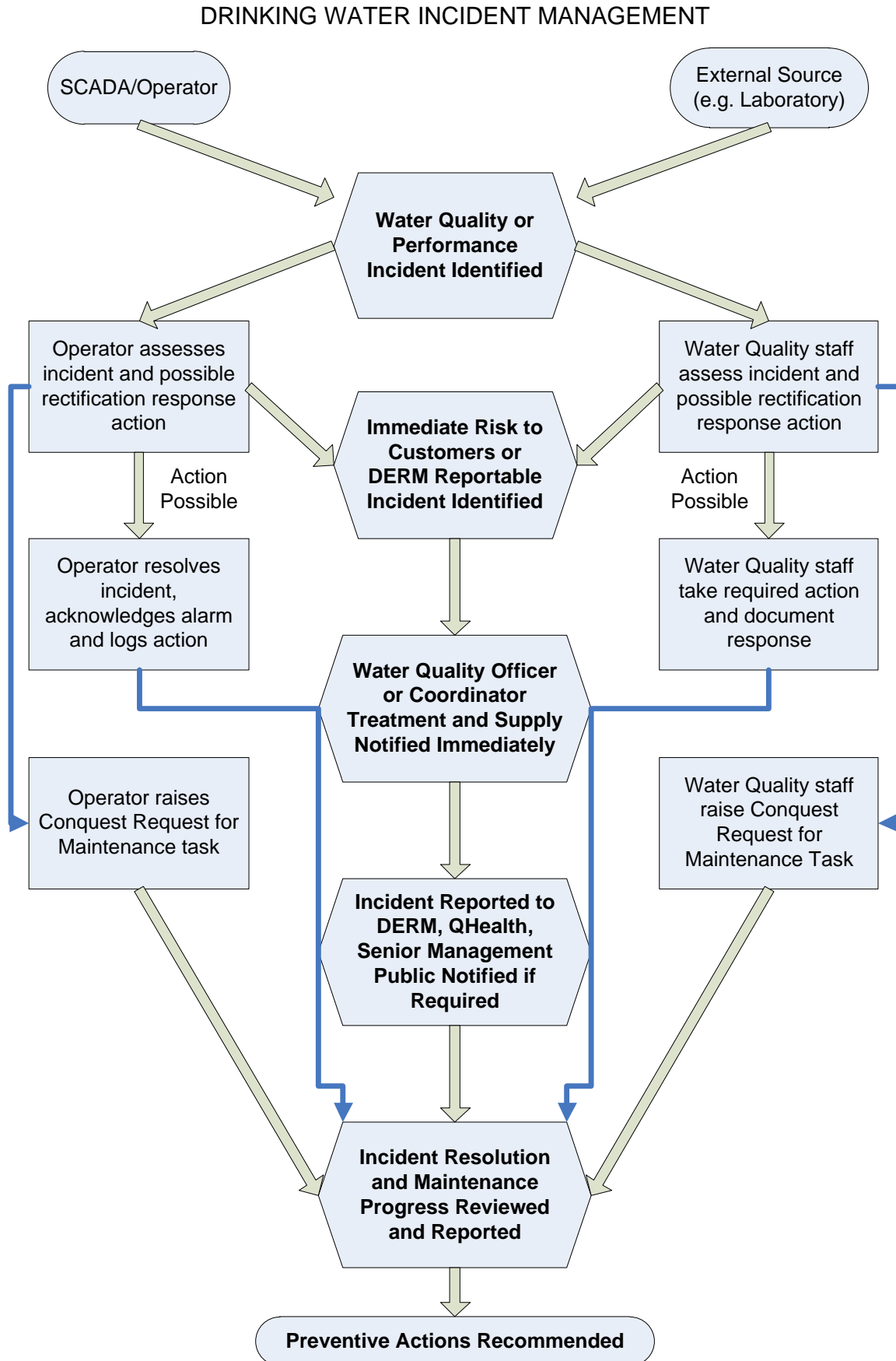

9 SERVICE WIDE SUPPORT – INFORMATION MANAGEMENT

Record keeping, information management and reporting activities are currently performed in a number of different ways depending on the type and source of the information and its intended use. The overarching approach to record keeping and record retention requirements is prescribed in Council’s Recordkeeping Policy (Policy No. POL.F4.7).

9.1 Information Management Systems

A number of different software systems are used to capture, manipulate and archive information relating to drinking water. These systems are accessible to all relevant staff through Council’s online IT services. Table 9.1 provides a listing of the software systems that are currently in use and provides an indication of how current or up-to-date the information is in each system. O&M Manuals and procedure documents are also stored in hardcopy. The group responsible for maintaining and updating each software system is also indicated.

Information is made available or distributed to all staff via Toolbox Meetings held each month or through specially organised meetings or training workshops as required. In addition, information is presented on noticeboards and important safety information provided to team members in document wallets that accompany each of the work vehicles used by staff. If required email or is used to distribute important information about drinking water operations and performance data.

Table 9.1: Software Systems Used for Management of Drinking Water Associated Information

System	Function	Group Responsible	Currency
DataWorks	Archiving of all business critical documents including internal and external correspondence	RRC Records Management	Current
Conquest	Management of all asset inventory, maintenance management information and all O&M Manuals	FRW Asset Management	Current
Pathways	Management of all customer engagements including complaints and information requests	RRC and FRW Admin	Current
Geko	Management of Council-wide GIS and asset location information	RRC and FRW Asset Management	95% current
Experion SCADA	Archiving of all on-line monitored operational data for drinking water infrastructure	FRW Treatment and Supply Team	Current
Microsoft Excel	Management of all water quality monitoring information	FRW Treatment and Supply Team	Current

9.2 Reporting Activities

Currently all reporting activities are managed by a number of teams within FRW although predominantly members of the Treatment and Supply Team are responsible for all reporting related to drinking water quality. Information for reporting purposes is obtained from Microsoft Excel files (e.g. drinking water quality testing results), SCADA archives (e.g. WTP performance metrics, flow measurements and

on-line drinking water quality results), Pathways archives (e.g. customer complaints) and Conquest archives (e.g. operating and maintenance activities).

Reports are prepared by key members of the Treatment and Supply Team (e.g. Water Quality Officer, Coordinator Treatment and Supply) and are reviewed by other members of the team and the Strategic Manager FRW prior to submission. In this manner, the many different internal and external reporting requirements associated with drinking water (e.g. Council reports, internal team performance reports, FRW Website reports for customers, drinking water quality compliance reports and drinking water quality incident reports) are generated to meet business and legislative obligations.

Fitzroy River Water is currently in the process of setting up SWIM-Local for all internal reporting activities associated with the operation and maintenance of drinking water infrastructure. This project is in the early stages of implementation and will continue to be worked on in the coming months towards completion later this financial year.

10 OPERATIONAL AND VERIFICATION MONITORING PROGRAMS

A comprehensive water quality monitoring program is in place to ensure that operational performance is maintained to a sufficiently high level in order to consistently produce drinking water that meets ADWG. Table 10.1 provides an overview of the water quality monitoring program in its entirety. The same monitoring program is applied across all drinking water schemes. The ADWG values for health and aesthetics are used as the compliance targets for the water quality monitoring program. The sampling locations and frequency recommended in the ADWG serve as the basis for the locations and sampling frequency applied for each water quality parameter in the monitoring program. Raw water sources are monitored in accordance with a Cyanobacteria Monitoring and Management Procedure based on best industry practice recommendations.

Unless specified, samples are grab samples and are delivered to external laboratories where required. Water quality staff use standard methods for sampling and sample handling with specialised containers and instructions supplied by analytical service providers incorporated in the sampling program. Additional detail on the operational monitoring conducted at each WTP and the detailed program for microbiological sampling across the drinking water schemes is provided below.

Excursions detected during operational or verification monitoring are managed according to the information outlined in the Section 8.

10.1 Operational Monitoring Within Drinking Water Scheme

Operational monitoring is performed at different stages in each drinking water scheme from catchment through to the distribution system. In particular, monitoring of the performance of key treatment barriers is a key focus of the operational monitoring conducted at each WTP. Table 10.2 provides a breakdown of the operational monitoring that is conducted within each drinking water scheme including

information on how the sampling is performed, its frequency and where defined, the operational targets or ranges (if applicable) for each parameter tested. Where stated in Table 10.2, ranges reflect the values between the high and low alarms around the SCADA setpoint for a given on-line operating parameter or water quality parameter. Values outside of this range therefore trigger an alarm which is responded to as described in Section 8.

Manual sampling listed as daily is also conducted more frequently on an event-related basis as required. The information provided for the Mount Morgan WTP is inclusive of the planned upgrade to install on-line monitoring of pH, electrical conductivity, turbidity and free chlorine at appropriate locations throughout the WTP; work which is currently nearing completion.

10.2 Verification Monitoring within Drinking Water Schemes

In addition to the verification monitoring program described in Table 10.1, drinking water is sampled weekly throughout each drinking water scheme for *E. coli*, free chlorine residual testing and other physico-chemical testing described below. Each week 15 drinking water samplings are tested for *E. coli*. A sample is collected from each WTP and 9 samples (Rockhampton 8, Mount Morgan 1) are collected from 57 possible sampling sites located throughout the two distribution systems. Table 10.3 provides a list of all the sampling sites that the weekly sampling schedule is rotated through. For example, each week a sample is collected from each of eight different supply zones within the Rockhampton Water Supply. The following week another seven supply zones, with some overlap with the preceding week, are sampled in order to rotate through all the different individual sampling sites over an extended period of time. A breakdown of the sampling locations based on supply zones and scheme is provided in Table 10.3. These supply zones are also identified in the water supply scheme schematics shown in Figures 2.1 to 2.3. Selection of the number and location of sampling sites was done in accordance with recommendations in the ADWG.

Table 10.1: Overview of Water Quality Monitoring Program for Each Drinking Water Scheme

Water Quality Parameter	ADWG Health Guideline	ADWG Aesthetic Guideline	Location Sampled*	Sampling Frequency# (ADWG Guide)
<i>E. coli</i>	0 cfu	No value	P, T, R	W, E (W)
<i>Cryptosporidium</i>	No value	No value	S, P	Y, E, (E)
<i>Giardia</i>	No value	No value	S, P	Y, E, (E)
Cyanobacteria	No value	No value	S, P	M, E, (M)
Cyanobacteria Toxin	Varies**	No value	S, P	E
pH	No value	6.5-8.5	S, P	C, D, (D, W)
Chlorine	5 mg/L	0.6 mg/L	P, T, R	C, D, (D,W)
Electrical Conductivity	No value	No value	S, P, R	C, D, M, (W,M)
Total Dissolved Solids	No value	600 mg/L	S, P	M
Colour	No value	15 HU	S, P	D, M, (W, M)
Turbidity	<1 NTU ^{&}	5 NTU	S, P, R	C, D, M, (D, W)
Total Hardness	No value	200 mg/L	S, P	M, (M)
Total Alkalinity	No value	No value	S, P	M, (W, M)
Sulphate	500 mg/L	250 mg/L	S, P	M, (Q)
Chloride	No value	250 mg/L	S, P	M, (Q)
Calcium	No value	No value	S, P	M, (Q)
Magnesium	No value	No value	S, P	M, (Q)
Sodium	No value	180 mg/L	S, P	M, (Q)
Potassium	No value	No value	S, P	M, (Q)
Aluminium (acid-soluble)	No value	0.2 mg/L	S, P	M, (D, W)
Copper	2 mg/L	1 mg/L	S, P	M, (M)
Lead	0.01 mg/L	No value	S, P	M, (M)
Manganese	0.5 mg/L	0.1 mg/L	S, P	M, (F)
Zinc	No value	3 mg/L	S, P	M, (M)
Iron	No value	0.3 mg/L	S, P	M, (M)
Fluoride	1.5 mg/L	No value	S, P	M (C, W)
Nitrite	3 mg/L	No value	S, P	M, (M)
Nitrate	50 mg/L	No value	S, P	M, (M)
Total Organic Carbon	No value	No value	S, P	Q, (M,Q)
Trihalomethanes	0.25 mg/L	No value	P, R	Q, (M)
Taste/odour compounds	No value	No value	S, P	E, (W, M)
Heavy Metals ^{>}	Various	No values	S, P	E, Y
Pesticides ^{>}	Various	No values	S	E, Y (M, E)
Perfluorocarbons	No values	No values	S, P	E, Y
Radionuclides	Various	No values	S	E, Y (5 years)

cfu = colony forming unit, HU = Hazen units, NTU = nephelometric turbidity units

* S = raw water source, P = treatment plant, T = transmission, R = reticulation

C = continuous (online), D = daily, W = weekly, F = fortnightly, M = monthly, Q = quarterly, Y = yearly, E = event related, ** Microcystins - <1.3 µg/L, no guideline value for other toxins, [>]See Appendix B for details of the heavy metals and pesticide testing, [&] <1 NTU target is for effective disinfection only with <0.2 NTU the target for filtration of protozoan pathogens

Table 10.2: Operational Monitoring Conducted within Each Drinking Water Scheme

Parameter	Location ^a	Frequency ^b	Target Values or Range
Rockhampton Water Supply Scheme			
Turbidity	RW, PS, PF, DW	D, On-line	PS (<1.5 NTU), PF (<0.3 NTU)
pH	RW, PF, PC, DW	D, On-line	PC & DW (pH 7.6-8.2)
Colour (true)	RW, DW	D	DW (<5 HU)
Dissolved Oxygen	DW	D	Not defined
Electrical Conductivity	PF, DW	D, On-line	<400 µS/cm
Total Dissolved Solids	DW	D	Not defined
Temperature	RW	D, On-line	Not defined
Taste and Odour	RW, DW	D	Not objectionable
Streaming Current	CD	On-line	Deviation monitoring
Free Chlorine	CW, DW, SR	D, On-line	DW (0.5-1.5mg/L), SR (0.5 - 1.5mg/L)
Mount Morgan Water Supply Scheme			
Turbidity	RW, PF, DW	D(RW), On-line	DW (<1.0 NTU)
pH	RW, PF, DW	D, On-line	CD (6.5-7.0), DW (pH 7.8)
Colour (true)	RW, DW	D	DW (<5 HU)
Alkalinity	RW, DW	W	DW (30 mg/L)
Electrical Conductivity	RW, PF, DW	D, On-line	<400 µS/cm
Temperature	RW	D	Not defined
Taste and Odour	RW, DW	D	Not objectionable
Free Chlorine	CW, DW, SR	D, On-line	DW (1.5 mg/L), SR (0.5-1.5mg/L)

^aRW = raw water, PS = post-sedimentation, PF = post-filtration, DW = final drinking water from outlet of clear water reservoir, CD = pre-filtration coagulant-dosed water, FD = fluoride dosed filtered water, CW = clear water inlet, SR = service reservoir, PC = post-pH correction

^bD = daily manual sampling, W = Weekly

Care has been taken to select a range of different sampling points so that there is good coverage of areas with different attributes. For example, points towards the extremity of reticulation supply zones have been chosen in some instances due to long water age, or known areas of limited free chlorine residual penetration. Examples of these sites include site MM2 in Baree on the Mount Morgan Water Supply Scheme, site LC1 on Lakes Creek Rd in Rockhampton, site MH4 on Somerset Rd in Gracemere or site MA1 at Sleipner St on Mt Archer in Rockhampton. One site in Mount Morgan was chosen as the area occasionally experiences low pressure as well as being at the extremity of the reticulation system. This MM4 site on Smalls Rd provides a good indication of the penetration of free chlorine residuals in the Mount Morgan Water Supply Scheme. In contrast, areas of known good free chlorine residual have also been selected so that the maximum levels of free chlorine reaching the customer's tap are able to be monitored in some instance.

Each week 11 samples are collected randomly from the designated reticulation sampling sites in each scheme for *E. coli* and free chlorine residual testing. Four (4) samples are also collected randomly from reticulation sampling sites located in North and South Rockhampton, Gracemere and Mt Morgan for pH, colour, turbidity and electrical conductivity measurements. This is to determine any gross changes in water quality at different locations in the distribution system. In this way, areas where water quality changes significantly due to events that occur in the distribution system will be identified and an investigation of possible causes commenced.

FRW spends a significant amount of time and effort responding to customer water quality complaints or comments about changes in water quality. This is done in order

to provide the best means of addressing the root cause of the water quality issue rather than only addressing the nature of the complaint. FRW receives a relatively low number of drinking water quality complaints from customers but understands the importance of using this information to help understand events or changes that occur in water quality and within the water distribution infrastructure.

The verification monitoring program in place is commensurate with the level of risk that exists within each of the water supply schemes based on the recent records of drinking water quality incidents or the frequency of drinking water quality complaints. Despite this, FRW intend to keep reviewing this monitoring program following some revision of the sections in the ADWG 2011 relevant to monitoring and also to further maximise the quality of drinking water supplied to customers. As with operational monitoring, if non-compliances or exceedances are detected during the verification monitoring program action is taken as described in Section 8.

Table 10.3: Drinking Water Distribution System Sampling Sites for Weekly Verification Monitoring (Supply Zone codes are labelled on reticulation areas in Figures 2.1 to 2.4)

Site Code	Reservoir Supply Zone	Address
Rockhampton Water Supply Scheme		
AL1	Agnes St Low Pressure System	O'Connell St
AL2		Cambridge St
AL3		Exhibition Rd
AL4		Ann St
AL5		Prospect St
AL6		Hunter St
AL7		Wandal Rd
AL8		Port Curtis Rd
AL9		Derby St
AL10		Denham St
AL11		Old Capricorn Hwy
AH1	Agnes St High Pressure System	Nathan St
AH2		North St
AH3		Herbert St
AH4		Jessie St
YR1	Yaamba Road Reservoir System	Bruigom St
YR2		Main St
YR3		Macallister St
YR4		Beaney St
YR5		Norman Rd
YR6		Maloney St
YR7		Rachel Drv
YR8		Robison St
TR1	Thozet Road Reservoir System	Earl St
TR2		Lucas St
TR3		Joiner St
TR4		Berserker St
TR5		Oshanesy St
MH1	Mawdesley Hill Reservoir System	O'Shanesy St
MH2		Ranger St
MH3		James St
MH4		Somerset Rd
LS1	Lucas St Reservoir System	Cherryfield Rd
LS2		Lillypilly Ave
LS3		Johnson Rd
LS4		Donovan Cres

Site Code	Reservoir Supply Zone	Address
FR1	Forbes Ave Reservoir System	Eichelberger St
FR2		Aldridge Ave
FR3		Frenchville Rd
ND1	Nagle Drv Reservoir System	Norman Rd
ND2		Selwyn Crs
ND3		Alyssa Court
PH1	Parkhurst Trunk Main System	McMillan Ave
PH2		Brosnan Crs
LC1	Lakes Ck Main	Lakes Creek Rd
MA1	Mount Archer	Sleipner St
SC1	Samuel Cres	Samuel Crs
SC2		Gremalis Dr
BD1	Parkhurst Industrial Estate	Bush Crs
RC1	Ramsay Creek Pumped Main	Bruce Hwy
Mount Morgan Water Supply Scheme		
MM1	Mount Morgan	Dee St
MM2		Creek St
MM3		River St
MM4		Smalls Rd
MM5		Gordon Ln

11 BEST PRACTICE INITIATIVES

FRW is actively engaged in a number of activities and initiatives which demonstrate an approach consistent with industry best practice for drinking water quality management. These activities include an ongoing commitment to drinking water quality management through stakeholder engagement towards improved catchment management, initiation and sponsoring of research and development projects and staff awareness and training activities. A commitment to the implementation of an approach that includes ongoing review and continual improvement is outlined in the RMIP detailed above.

11.1 Commitment to Drinking Water Quality Management

FRW is involved in a number of key stakeholder initiatives designed to provide guidance to the overall management and monitoring of water quality and environmental health in the Fitzroy Basin. This Fitzroy River Basin is a very important part of Central Queensland with the vast majority of residents within RRC now dependent on the provision of safe drinking water sourced from the Fitzroy River. Management of the health of the catchment and the minimisation of the impact of catchment land use activities is therefore a key priority. FRW's ongoing involvement in the Fitzroy Water Quality Advisory Group established following the Ensham Mine discharge event in 2008, and its active participation in the Strategic Working Group at the embryonic stages of the Fitzroy Partnership for River Health underpins this commitment.

11.2 Research and Development Activities

Over the last three years FRW has strengthened its collaborative ties with researchers at Central Queensland University. FRW has been involved in the initiation and funding of two research projects. The first project focused on developing an understanding of the diversity and abundance of micro-fungi within parts of the Rockhampton Water Supply Scheme. This PhD project generated very useful data related to the prevalence of micro-fungi and the role of frogs and aerosols in the contamination of service reservoirs.

The second project focused on the optimisation of treatment chemicals and associated processes for the optimisation of the removal of toxic species of cyanobacteria from the Fitzroy River raw water. Through this project FRW gained an insight into the effectiveness of different treatment options for the removal of the known toxin producer *Cylindrospermopsis raciborskii* – one of the more abundant population members during cyanobacterial blooms in the Fitzroy River.

Recently, Fitzroy River Water commenced working with colleagues in the Water Quality and Health Network (Water Services Association of Australia) to review the options and impacts of the implementation of health-based targets for pathogens in the schemes operated by Fitzroy River Water. This involves participating in surveys and completing a review of existing treatment process performance.

More recently the Department of Science, Information Technology, Innovation and the Arts established a mutual collaboration with FRW to manually collect water quality samples at the GWTP inlet structure which represents the Fitzroy River end-of-system site of the Great Barrier Reef loads monitoring program. Although the data collected is still in its infancy, it provided an insight on suspended solids, nutrients and pesticides concentrations during baseflow and high flow event conditions.

11.3 Staff Awareness and Training

The importance of drinking water quality and the role of team members at FRW in the delivery of safe and reliable drinking water to the community is a topic that is emphasised regularly at staff Toolbox Meetings and during day to day activities. As continual improvements are made to operating procedures or infrastructure upgrades are completed, the significance of these changes with respect to improvements in water quality and levels of service are discussed and relevant training is provided. Equally, the importance of delivering a high quality drinking water service is emphasised to promote a culture of proactive behaviour, innovation and ownership of service delivery.

12 RISK MANAGEMENT IMPROVEMENT PROGRAM

FRW and RRC are committed to delivering safe and reliable drinking water services to the community. To ensure that this is achieved, and to minimise the risks posed to the current drinking water services, a Risk Management Improvement Program has been prepared that comprises five elements. These are:

- Element 1 - Infrastructure Upgrades and Improved Infrastructure Performance
- Element 2 - Optimisation of Information Management and Reporting Capabilities
- Element 3 - Enhanced Engagement with Stakeholders Associated with Drinking Water Infrastructure Management
- Element 4 - Improved Service Through Staff Awareness and Training
- Element 5 - Enhanced Water Quality Performance

Table 12.1 provides an overview of the outputs, priority level, timeframe for completion and availability of funding for each of the five Elements identified in the Risk Improvement Management Program. Table 12.2 provides a specific detail for each action identified as being required to mitigate the unacceptable residual risk ratings listed in Table 6.1 and also other areas where further actions have been identified as being required. The current status and timeframes and person responsible for the completion of these actions are also listed.

Table 12.1: Risk Management Improvement Program for Drinking Water Services

Element	Outputs	Priority Level	Timeframe for Completion	Funding Availability
Element 1 Infrastructure Upgrades and Improved Infrastructure Performance	Complete all capital upgrades to water supply infrastructure to mitigate unacceptable risks identified in Table 6.1	High	Ongoing	Yes
Element 2 Information Management and Reporting Capability Enhancement	Consolidated and streamlined information management and reporting processes	High	September 2015	Yes
Element 3 Enhanced Stakeholder Engagement	Influence on stakeholders delivers improved management of catchments and other water infrastructure	High	Ongoing	Yes
Element 4 Improved Service through Staff Awareness and Training	Deliver the DWQMP to staff and develop culture of awareness of drinking water quality management. Deliver appropriate training	High	Ongoing	Yes
Element 5 Enhanced Water Quality Performance	Deliver ongoing improvements to drinking water quality, safety and reliability.	High	Ongoing	Yes

Table 12.1: Specific Actions Identified to Mitigate Unacceptable Risks to Drinking Water Quality and Information Describing these Actions.

Risk No.	Component-Event-Hazard	RRR	Proposed Action	Responsible Officer	Status	Completion Date
Rockhampton Water Supply Scheme						
R08	Source – Contamination of raw water Excessive E.C. or TDS	M9	Continue to lobby regulator for tighter water quality limits on mine water discharges.	Coordinator Treatment and Supply	Ongoing	N/A
R13	Treatment – Lack of effective treatment Viral Pathogens	M5	Perform testing for viruses for further confirmation of process effectiveness.	Water Quality Officer	Planning	30/06/2015
R30	Distribution – Sabotage or Terrorism Toxic agent	M5	Identify high risk sites and install CCTV at these sites.	Coordinator Treatment and Supply	Planning	30/06/2015
R33	Customers Tap – Contamination Microbial Pathogens	M5	Create a website Fact Sheet warning of risks of contamination at customer tap	Water Quality Officer	Planning	30/06/2015
Mount Morgan Water Supply Scheme						
MM12	Treatment – Lack of effective treatment Protozoan Pathogens	M8	Use newly installed on-line analysis to drive further process optimisation.	Coordinator Treatment and Supply	Ongoing	N/A
MM13	Treatment – Lack of effective treatment Toxic Cyanobacteria	M8	Further optimise cyanobacteria removal. Conduct more analysis to determine effectiveness of each treatment barrier for removal of cyanobacteria.	Coordinator Treatment and Supply	In progress	30/06/2015
MM14	Treatment – Lack of effective treatment Viral Pathogens	M8	Perform testing for viruses for further confirmation of process effectiveness.	Water Quality Officer	Planning	30/06/2015
MM18	Treatment – Lack of effective treatment Excessive Turbidity	M5	Use newly installed on-line analysis to drive further process optimisation.	Coordinator Treatment and Supply	Ongoing	N/A
MM20	Treatment – Process control failure Coagulant Underdose	M6	Convert coagulant dosing to liquid alum to allow for on-line flow metering and better measurement of chemical usage.	Coordinator Treatment and Supply	Underway	31/12/2014
MM32	Distribution – Sabotage or Terrorism Toxic agent	M5	Identify high risk sites and install CCTV at these sites.	Coordinator Treatment and Supply	Planning	30/06/2015
MM36	Customers Tap – Contamination Microbial Pathogens	M6	Create a website Fact Sheet warning of risks of contamination at customer tap	Water Quality Officer	Planning	30/06/2015

N/A = Not applicable

APPENDIX A

Likelihood Rating Table

Likelihood	Description
5. Almost Certain	Occurs more often than once per week (52/yr)
4. Likely	Occurs more often than once per month (12/yr) and up to once per week (52/yr)
3. Possible	Occurs more often than once per year and up to once per month (12/yr)
2. Unlikely	Occurs more often than once every five years and up to once per year
1. Rare	Occurs less than or equal to once every five years

Consequence Rating Table

Consequence	Description
5. Catastrophic	Potential acute health impact, declared outbreak expected
4. Major	Potential acute health impact, no declared outbreak expected
3. Moderate	Potential widespread aesthetic impact or repeated breach of chronic health parameter
2. Minor	Potential local aesthetic, isolated exceedance of chronic health parameter
1. Insignificant	Isolated exceedance of aesthetic parameter with little or no disruption to normal operation

Risk Rating Matrix

Likelihood	Consequence				
	1. Insignificant	2. Minor	3. Moderate	4. Major	5. Catastrophic
5. Almost Certain	Medium 6	High 10	High 15	Extreme 20	Extreme 25
4. Likely	Medium 5	Medium 8	High 12	High 16	Extreme 20
3. Possible	Low 3	Medium 6	Medium 9	High 12	High 15
2. Unlikely	Low 2	Low 4	Medium 6	Medium 8	High 10
1. Rare	Low 1	Low 2	Low 3	Medium 5	Medium 6

Uncertainty Ratings

Uncertainty	Description
Certain	There is 5 years of continuous monitoring data which has been trended and assessed with at least daily monitoring. The processes involved are thoroughly understood.
Confident	There is 5 years of continuous monitoring data which has been trended and assessed with at least weekly monitoring or for the duration of seasonal events. There is good understanding of the processes involved.
Reliable	There is at least a year of continuous monitoring data available which has been assessed. There is a good understanding of the processes involved.
Estimate	There is limited monitoring data available. There is a reasonable understanding of the processes involved.
Uncertain	There is limited or no monitoring data available. Processes are not well understood.

APPENDIX B

Example Heavy Metal and Pesticide Test Results

Page : 3 of 8
 Work Order : EB1120053
 Client : ROCKHAMPTON REGIONAL COUNCIL
 Project : Monthly Water Quality Physical Anions Cations



Analytical Results

Sub-Matrix: WATER				Client sample ID	Glenmore Potable	Glenmore Raw	Woodbury Potable	Woodbury Raw	Mt Morgan Potable
				Client sampling date / time	28-SEP-2011 15:00	28-SEP-2011 15:00	28-SEP-2011 15:00	28-SEP-2011 15:00	27-SEP-2011 15:00
Compound	CAS Number	LOR	Unit	EB1120053-001	EB1120053-002	EB1120053-003	EB1120053-004	EB1120053-005	
EG020T: Total Metals by ICP-MS									
Arsenic	7440-38-2	0.001	mg/L	<0.001	0.001	<0.001	<0.001	<0.001	<0.001
Cadmium	7440-43-9	0.0001	mg/L	<0.0001	<0.0001	<0.0001	<0.0001	<0.0001	<0.0001
Chromium	7440-47-3	0.001	mg/L	<0.001	<0.001	<0.001	<0.001	<0.001	<0.001
Nickel	7440-02-0	0.001	mg/L	<0.001	0.002	<0.001	<0.001	<0.001	<0.001
Selenium	7782-49-2	0.01	mg/L	<0.01	<0.01	<0.01	<0.01	<0.01	<0.01
EG035T: Total Recoverable Mercury by FIMS									
Mercury	7439-97-6	0.0001	mg/L	<0.0001	<0.0001	<0.0001	<0.0001	<0.0001	<0.0001

Page : 4 of 8
 Work Order : EB1120053
 Client : ROCKHAMPTON REGIONAL COUNCIL
 Project : Monthly Water Quality Physical Anions Cations

Analytical Results

Sub-Matrix: WATER				Client sample ID	No 7 Dam Raw	Fletchers Ck	Glenmore Raw	Woodbury Raw	No 7 Dam Raw
				Client sampling date / time	27-SEP-2011 15:00	27-SEP-2011 15:00	28-SEP-2011 15:00	28-SEP-2011 15:00	27-SEP-2011 15:00
Compound	CAS Number	LOR	Unit	EB1120053-006	EB1120053-007	EB1120053-008	EB1120053-009	EB1120053-010	
EG020T: Total Metals by ICP-MS									
Arsenic	7440-38-2	0.001	mg/L	<0.001	<0.001	---	---	---	
Cadmium	7440-43-9	0.0001	mg/L	<0.0001	<0.0001	---	---	---	
Chromium	7440-47-3	0.001	mg/L	<0.001	<0.001	---	---	---	
Nickel	7440-02-0	0.001	mg/L	<0.001	<0.001	---	---	---	
Selenium	7782-49-2	0.01	mg/L	<0.01	<0.01	---	---	---	
EG035T: Total Recoverable Mercury by FIMS									
Mercury	7439-97-6	0.0001	mg/L	<0.0001	<0.0001	---	---	---	
EP130A: Organophosphorus Pesticides (Ultra-trace)									
Bromophos-ethyl	4824-78-6	0.10	µg/L	---	---	<0.10	<0.10	<0.10	
Carbophenothion	786-19-6	0.10	µg/L	---	---	<0.10	<0.10	<0.10	
Chlorfenvinphos (Z)	18708-87-7	0.10	µg/L	---	---	<0.10	<0.10	<0.10	
Chlorpyrifos	2921-88-2	0.050	µg/L	---	---	<0.050	<0.050	<0.050	
Chlorpyrifos-methyl	5598-13-0	0.10	µg/L	---	---	<0.10	<0.10	<0.10	
Demeton-S-methyl	919-86-8	0.10	µg/L	---	---	<0.10	<0.10	<0.10	
Diazinon	333-41-5	0.10	µg/L	---	---	<0.10	<0.10	<0.10	
Dichlorvos	62-73-7	0.10	µg/L	---	---	<0.10	<0.10	<0.10	
Dimethoate	60-51-5	0.10	µg/L	---	---	<0.10	<0.10	<0.10	
Ethion	563-12-2	0.10	µg/L	---	---	<0.10	<0.10	<0.10	
Fenamiphos	22224-92-6	0.10	µg/L	---	---	<0.10	<0.10	<0.10	
Fenthion	55-38-9	0.10	µg/L	---	---	<0.10	<0.10	<0.10	
Malathion	121-75-5	0.10	µg/L	---	---	<0.10	<0.10	<0.10	
Azinphos Methyl	86-50-0	0.10	µg/L	---	---	<0.10	<0.10	<0.10	
Monocrotophos	6923-22-4	0.10	µg/L	---	---	<0.10	<0.10	<0.10	
Parathion	56-38-2	0.10	µg/L	---	---	<0.10	<0.10	<0.10	
Parathion-methyl	298-00-0	0.10	µg/L	---	---	<0.10	<0.10	<0.10	
Pirimphos-ethyl	23505-41-1	0.10	µg/L	---	---	<0.10	<0.10	<0.10	
Prothiofos	34643-46-4	0.10	µg/L	---	---	<0.10	<0.10	<0.10	
EP131A: Organochlorine Pesticides									
Aldrin	309-00-2	0.010	µg/L	---	---	<0.010	<0.010	<0.010	
alpha-BHC	319-84-6	0.010	µg/L	---	---	<0.010	<0.010	<0.010	
beta-BHC	319-85-7	0.010	µg/L	---	---	<0.010	<0.010	<0.010	
delta-BHC	319-86-8	0.010	µg/L	---	---	<0.010	<0.010	<0.010	
4,4'-DDD	72-54-8	0.010	µg/L	---	---	<0.010	<0.010	<0.010	
4,4'-DDE	72-55-9	0.010	µg/L	---	---	<0.010	<0.010	<0.010	
4,4'-DDT	50-29-3	0.010	µg/L	---	---	<0.010	<0.010	<0.010	
^ Sum of DDD + DDE + DDT	---	0.010	µg/L	---	---	<0.010	<0.010	<0.010	
Dieldrin	60-57-1	0.010	µg/L	---	---	<0.010	<0.010	<0.010	
alpha-Endosulfan	959-98-8	0.010	µg/L	---	---	<0.010	<0.010	<0.010	

A Campbell Brothers Limited Company

Page : 5 of 8
 Work Order : EB1120053
 Client : ROCKHAMPTON REGIONAL COUNCIL
 Project : Monthly Water Quality Physical Anions Cations

Analytical Results

Sub-Matrix: WATER				Client sample ID	No 7 Dam Raw	Fletchers Ck	Glenmore Raw	Woodbury Raw	No 7 Dam Raw
				Client sampling date / time	27-SEP-2011 15:00	27-SEP-2011 15:00	28-SEP-2011 15:00	28-SEP-2011 15:00	27-SEP-2011 15:00
Compound	CAS Number	LOR	Unit	EB1120053-006	EB1120053-007	EB1120053-008	EB1120053-009	EB1120053-010	
EP131A: Organochlorine Pesticides - Continued									
beta-Endosulfan	33213-65-9	0.010	µg/L	---	---	<0.010	<0.010	<0.010	
Endosulfan sulfate	1031-07-8	0.010	µg/L	---	---	<0.010	<0.010	<0.010	
Endosulfan (sum)	115-29-7	0.010	µg/L	---	---	<0.010	<0.010	<0.010	
Endrin	72-20-8	0.010	µg/L	---	---	<0.010	<0.010	<0.010	
Endrin aldehyde	7421-93-4	0.010	µg/L	---	---	<0.010	<0.010	<0.010	
Endrin ketone	53494-70-5	0.010	µg/L	---	---	<0.010	<0.010	<0.010	
Heptachlor	76-44-8	0.005	µg/L	---	---	<0.005	<0.005	<0.005	
Heptachlor epoxide	1024-57-3	0.010	µg/L	---	---	<0.010	<0.010	<0.010	
Hexachlorobenzene (HCB)	118-74-1	0.010	µg/L	---	---	<0.010	<0.010	<0.010	
gamma-BHC	58-89-9	0.010	µg/L	---	---	<0.010	<0.010	<0.010	
Methoxychlor	72-43-5	0.010	µg/L	---	---	<0.010	<0.010	<0.010	
cis-Chlordane	5103-71-9	0.010	µg/L	---	---	<0.010	<0.010	<0.010	
trans-Chlordane	5103-74-2	0.010	µg/L	---	---	<0.010	<0.010	<0.010	
Total Chlordane (sum)	---	0.010	µg/L	---	---	<0.010	<0.010	<0.010	
Oxychlordane	27304-13-8	0.010	µg/L	---	---	<0.010	<0.010	<0.010	
EP130S: Organophosphorus Pesticide Surrogate									
DEF	78-48-8	0.1	%	---	---	63.2	103	105	
EP131S: OC Pesticide Surrogate									
Dibromo-DDE	21655-73-2	0.1	%	---	---	40.4	76.9	80.8	

Schedule 2

*FRW and LSC Operating
Protocol*

December 16
2013

Operating protocol between Fitzroy River Water (FRW) and
Livingstone Shire Council (LSC) for the supply of water and
sewerage services

1	REGISTERED SERVICE DETAILS.....	6
1.1	Service Provider Name.....	6
1.2	Drinking Water Service Operator.....	6
1.3	Drinking Water Schemes Covered By This Plan.....	6
1.4	Current Details for Location, Size and Demand of Drinking Water Schemes.....	6
2	DETAILS OF DRINKING WATER SCHEME INFRASTRUCTURE.....	8
2.1	Overview of Scheme Infrastructure.....	8
2.2	Water Sources for Drinking Water Supply.....	14
2.3	Water Treatment Processes.....	16
2.4	Availability of Equipment and Critical Spares.....	21
2.5	Water Distribution and Reticulation Infrastructure.....	22
2.6	Stakeholders Involved in Managing Drinking Water Infrastructure.....	31
3	CATCHMENT AND WATER QUALITY INFORMATION.....	32
3.1	Catchment Characteristics.....	32
3.2	Raw Water and Drinking Water Quality.....	34
3.3	Drinking Water Quality Incidents.....	39
3.4	Drinking Water Quality Complaints.....	40
4	HAZARD IDENTIFICATION.....	41
5	ASSESSMENT OF RISKS.....	43
6	MANAGING RISKS.....	61
6.1	Unacceptable Risks to Drinking Water Quality.....	61
7	OPERATION AND MAINTENANCE PROCEDURES.....	62
7.1	Manuals and Procedures for Drinking Water Schemes.....	62
7.2	Preventative Maintenance Program.....	63
7.3	Reactive Maintenance Management.....	64
8	MANAGEMENT OF EMERGENCIES, INCIDENTS, OR EXCURSIONS FROM NORMAL PERFORMANCE.....	64
8.1	Emergency Response Plan.....	64
8.2	Managing Drinking Water Incidents or Excursions from Normal Operational Performance.....	64
8.3	Emergency Contact Information.....	67
9	SERVICE WIDE SUPPORT – INFORMATION MANAGEMENT.....	69
9.1	Information Management Systems.....	69
9.2	Reporting Activities.....	69
10	OPERATIONAL AND VERIFICATION MONITORING PROGRAMS.....	70
10.1	Operational Monitoring Within Drinking Water Scheme.....	70
10.2	Verification Monitoring within Drinking Water Schemes.....	71
11	BEST PRACTICE INITIATIVES.....	75
11.1	Commitment to Drinking Water Quality Management.....	75
11.2	Research and Development Activities.....	76
11.3	Staff Awareness and Training.....	76
12	RISK MANAGEMENT IMPROVEMENT PROGRAM.....	77
•	Document Control.....	87
•	<i>Revision control</i>	87
•	<i>Protocol effective date</i>	88

•	Key contract for Schedule owner	88
•	Revisions schedule	89
•	Background	90
•	Objectives	91
•	Scope	91
•	Key Principles Underpinning Protocols	92
•	Schedule 2 Overview	93
•	<i>Protocol Exceptions</i>	93
•	<i>Interactions with statutory obligations</i>	93
•	<i>Risk</i>	93
•	<i>Responsibilities</i>	93
•	<i>Communications conventions</i>	93
•	<i>Water and Sewerage Operations Working Group</i>	94
•	Information sharing	94
•	Bulk Water Transfer/Metering Points	94
•	7.1 Bulk Metering Installations	94

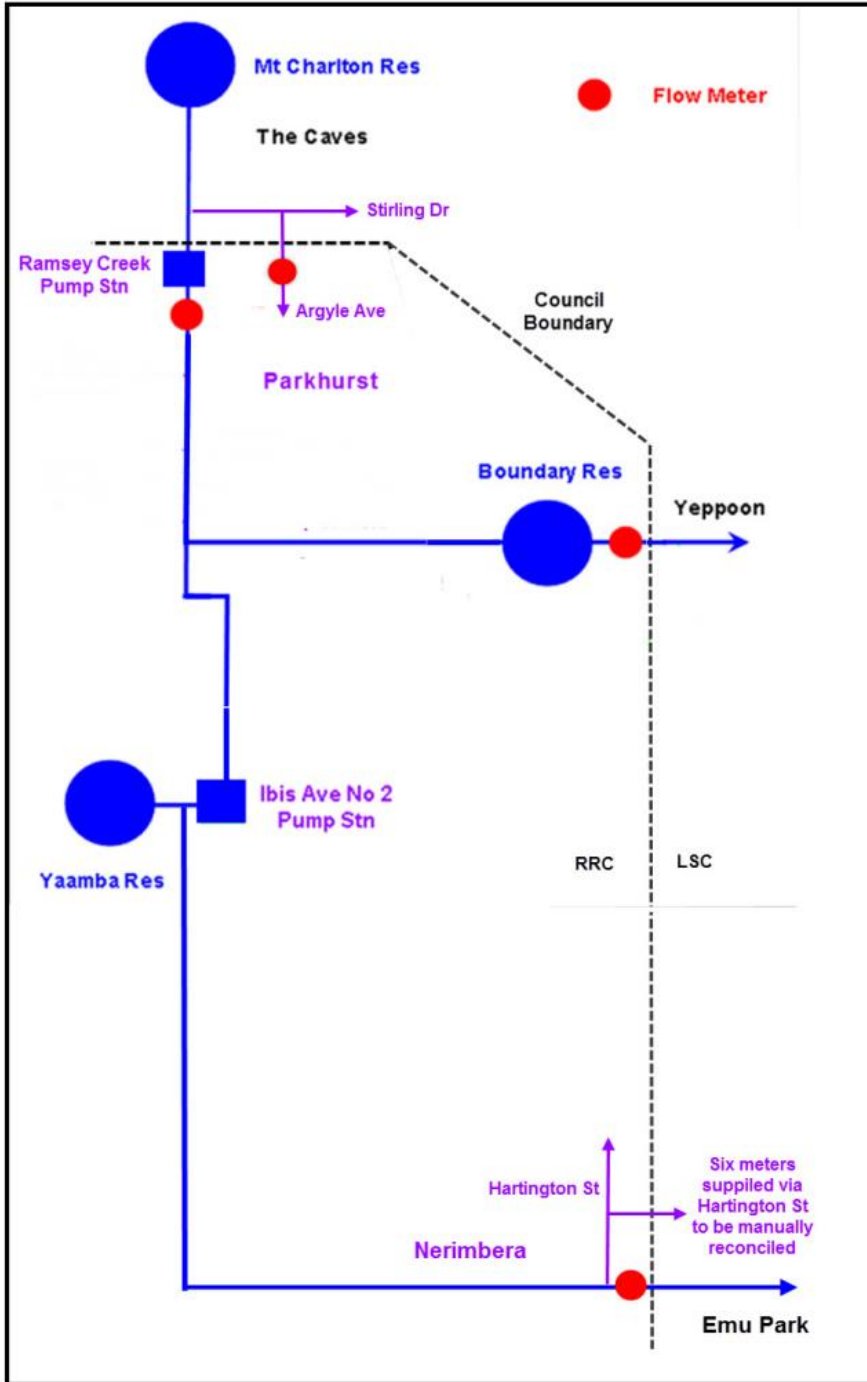

.....95

- **“Good Operating Practice”**96
- **Responding to Network Operational Instructions**96
 - *Purpose and Scope* 96
 - *Responsibilities and Accountabilities* 96
- **Water Quality and Disinfection Management**.....98
 - *Purpose and Scope*..... 98
 - *Responsibilities and Accountabilities* 98

- **Asset Management.....99**
 - *Purpose and Scope*..... 99
 - *Responsibilities and Accountabilities* 99
- **Security and site access.....99**
 - *Purpose and scope* 99
 - *Responsibilities and Accountabilities* 99
- **Risk and Incident Management.....101**
 - *Purpose and Scope*..... 101
 - *Responsibilities & Accountabilities* 101
- **Provision of SCADA Data101**
 - *Purpose and Scope*..... 101
 - *Responsibilities and Accountabilities* 101
 - *Nature of SCADA Data Request* 102
 - *Submitting a Request for SCADA Data*..... 102
 - *Provision of SCADA Data* 102
 - *Provision of SCADA Network Transmission Sites*..... 102
- **Operational Controls.....103**
 - *Purpose and Scope*..... 103
 - *Responsibilities and Accountabilities* 103
 - *Site specific requirements*..... 103
- **Stakeholder and Media Management104**
 - *Purpose and Scope*..... 104
 - *Responsibilities and Accountabilities* 104
- **Definition and Glossary of Terms105**
- **Review Date.....105**
- **Addendum A – Key Stakeholders List107**
 - *Fitzroy River Water*..... 107
 - *Livingstone Shire Council* 107
- **Addendum B – Key Sites List.....108**
 - *Fitzroy River Water*..... 108
 - *Livingstone Shire Council* 108

- **Document Control**

- *Revision control*

Version	Date	Prepared / changed by	Summary of Change
0.1	30-10-13	Chris Mills (KPMG)	Initial document outline created
0.2	21-11-13	Evan Davison (FRW)	Modifications to additional draft supplied

0.3	22-11-13	Jason Plumb (FRW)	Additions made to technical content for proposed operating arrangements
0.4	04-11-13	Alex Lai (KPMG)	Amendments made based on meeting with Jason Plumb and Evan Davison (on 04/12 and 27/11)
0.5	05-12-13	Alex Lai (KPMG)	Final draft amendments made based on meeting with Dan Toon and Nimish Chand (04/12)
0.6	11-12-13	Alex Lai (KPMG)	Updates based on clarification meeting on 11.12.2013 with Dan, Nimish, Jason and Sean.
1.0	16-12-13	Alex Lai (KPMG)	Final issue to Dan and Nimish for approval.

- **Protocol effective date**

Effective from	1 January 2013
Nominated review date	1 July 2014

- **Key contract for Schedule owner**

Fitzroy River Water Contact	Contact Name	Nimish Chand – Manager Fitzroy River Water
	Contact Landline	07 4936 8720
	Contact Mobile	0400 025 798
	Contact Email	Nimish.chand@rrc.qld.gov.au
Livingstone Shire Council Contact	Contact Name	Dan Toon -
	Contact Landline	07 49399810
	Contact Mobile	0419687931
	Contact Email	Dan.toon@lsc.qld.gov.au

- **Revisions schedule**

Version	Date	Reviewed by	Endorsed by
1.0	16/12/2013		Nimish Chand
1.0	16/12/2013		Dan Toon
0.3 and 0.4	04/12/2013	Jason Plumb and Evan Davis	
0.5	04/12/2013	Nimish Chand	
0.5	05/12/2013	Dan Toon	
0.5	05/12/2013	Sean Fallis	
0.6	11/12/2013	Jason Plumb	
0.6	11/12/2013	Nimish Chand	
0.6	11/12/2013	Dan Toon	
0.6	11/12/2013	Sean Fallis	

- **Background**

Fitzroy River Water (FRW) is a commercialised business unit of the Rockhampton Regional Council (RRC), and is responsible for the delivery of water and sewerage services to all RRC ratepayers. The delivery of these services includes the supply of drinking water from the Glenmore Water Treatment Plant (GWTP) to three separate locations that will soon become part of the newly (re-) formed Livingstone Shire Council (LSC). These three locations are the areas of The Caves Water Supply Scheme and the Nerimbera Water Supply Scheme to the north and south of Rockhampton respectively, and the Capricorn Coast Water Supply Scheme which is connected to the Rockhampton Water Supply Scheme via the Rockhampton to Yeppoon Water Supply Pipeline (Pipeline).

The infrastructure that supplies drinking water to these locations is currently owned, operated and maintained by RRC. As part of the de-amalgamation of the LSC from RRC, some of the infrastructure used to supply drinking water to the new LSC will change with respect to ownership and operating and maintenance responsibility. Critical to the separation of this infrastructure from RRC, a SCADA separation project has been initiated to allow LSC to separate all relevant telemetry networks and SCADA systems in order to ensure safe and reliable operation of water and sewerage infrastructure to meet the needs of the new Council.

The new LSC will commence as a local government authority and water service provider on 1 January 2014. The completion of the SCADA separation project is expected to occur by the end of April 2014. In lieu of the completion of this separation project and in order to ensure a smooth transition occurs, FRW will continue to provide the current level of telemetry and SCADA monitoring capability up until 30 June 2014, or sooner upon completion of the Scada Separation Project . Up to and beyond this time, the water and sewerage infrastructure in the two separated Councils will predominantly be operated as separate infrastructure in accordance with the arrangements defined in this Schedule.

Both LSC and FRW aim to provide transitional services to support one another as they undergo a full separation of its water and sewerage SCADA networks and systems. Under Addendum C, it consists of the short term transitional services (starting from 1 January 2014 for 6 months) that look to provide ad-hoc support, network hosting and transmission services, knowledge transfer and data restoration services for both FRW and LSC SCADA environments.

- **Objectives**

The objectives of this Schedule are as follows:

- To define and achieve a cooperative relationship between FRW and the LSC, towards ensuring the safe and reliable supply of water and sewerage services by each Council.
- To acknowledge that there will be co-dependencies between FRW and the LSC due to the physical connections between parts of the water supply infrastructure in each Council.
- To define any arrangements that will be required to ensure the effective operation and maintenance of infrastructure essential to the supply of water and sewerage services by FRW and LSC.
- To define where and how bulk water metering will take place, and how the quantity (demand) and quality of the water supplied from FRW to the LSC will be managed.
- Define the service arrangements, service levels and responsibilities during the short term transitional period from 1 January 2014 to 30 June 2014. Refer to Addendum C.

- **Scope**

This Schedule covers all aspects relevant to the operation and maintenance of co-dependent or physically connected assets that when combined comprise the infrastructure required to supply drinking water from FRW to LSC or to ensure the effective operation of any other water and sewerage infrastructure in LSC.

These aspects include the day to day accessibility, operation and maintenance of co-dependent infrastructure as well as short term and long term future planning of the required usage of the co-dependent infrastructure. Specific information about key assets is detailed in Section 7 of this protocol.

- **Key Principles Underpinning Protocols**

Schedule key principles are as follows:

- 1 To enable both parties (LSC and FRW) to better coordinate their activities and to clearly state expectations relating to operation and maintenance activities associated with water and sewerage infrastructure. This will enable the following to be carried out with absolute minimal impact on the other party's infrastructure or levels of service:
 - Planned system maintenance;
 - Reactive system maintenance;
 - Successful delivery of capital works programs;
 - Analysis of current supply requirements; and
 - Predictions relating to future supply requirements.
- 2 The parties will also develop a clear understanding of the consultation requirements and processes for the commissioning and/or scheduling of the following:
 - New infrastructure;
 - Major planned system maintenance;
 - Significant operational changes to existing infrastructure;
 - Capacity limitations and/or constraints; and
 - Relevant variations to operational procedures.
- 3 Site access will require that agreed processes related to Workplace Health and Safety, site security and maintenance management are followed. Parties to this protocol will work cooperatively together to arrange/schedule access as required.
- 4 Where policies, service standards and processes are yet to be developed for the newly form LSC, policies, standards and processes from FRW and RRC will be adopted and applied where reasonable to do so.
- 5 Determine reference and/or assessment criteria to be used in assessing the effectiveness of the protocol once implemented.

- **Schedule 2 Overview**

This Schedule provides the framework for both parties to manage any interactions associated with the delivery of water and sewerage services related to shared or co-dependent assets, in line with good operating practices.

- ***Protocol Exceptions***

Protocols agreed between the parties that are outside the scope of this Schedule are exempt and will continue in place.

- ***Interactions with statutory obligations***

Water service providers or owners of water storage infrastructure are required to comply with current statutory regulations, which will take precedence,

- ***Risk***

Risk will be managed as per current policies and procedures in place at FRW.

Each party is responsible for managing its risks and each party acknowledges that other parties to this Schedule will manage their own relevant risks. Nonetheless, any specific new or emerging risk identified by either party that has the potential to pose a significant risk to the other party's ability to supply water should be brought to the attention of the other party, in line with Customer Service Standards. For example, a problem or fault at a shared telemetry site. The Network Operating Instructions will assist both parties in better managing their risks and the risks to the water reticulation network and associated infrastructure.

- ***Responsibilities***

Responsibilities of the parties to this Schedule are outlined in specific section of this Schedule. The parties also undertake to act, within their powers and capacity, in such a manner that maintains the functional operations of their and the other's water and sewerage services.

- ***Communications conventions***

Addendum B details the list of contact people for any queries or concerns regarding the documented protocols.

All communications between the parties are to be via email or phone and all requests from one party to another must be acknowledged with a return email or phone and all requests from one party to another must be acknowledged with a return email or phone response.

During the transitional period, a communications plan is to be developed, agreed, implemented, and maintained between both parties covering the following:

- Media Management / Issue Management;
- Stakeholder Relationship Management;
- Operational Management; and
- Escalation Process.

An appropriate in-hours and after-hours contact procedures protocol for emergency contact etc (including escalation protocol) shall be established as part of the Incident Management Process.

- ***Water and Sewerage Operations Working Group***

The Water and Sewerage Operations Working Group (WSOWG) or their delegates from FRW and LSC comprise this working group. The key role is to facilitate efficient 'day to day' operational tasks (with their respective regions) defined within this document.

The WSOWG shall review the effectiveness of the Operating Procedure document on a regular basis.

- **Information sharing**

Both parties commit to share information and enable data transfer to support the proper functioning and continuous improvement of the Operating Protocols.

Both parties will develop and agree on processes to address inconsistencies in data and acknowledge that the data is only provided for the purposes of this Schedule.

- **Bulk Water Transfer/Metering Points**

- ***7.1 Bulk Metering Installations***

A bulk metering installation point is defined as the location within the bulk water distribution system at which the transfer of water from FRW to the LSC water distribution system occurs and is metered for billing purposes. These bulk metering points are generally located within close proximity to the boundary between RRC and LSC. In one instance where a small number of properties are involved (Hartington

Street), bulk meters have been deemed unnecessary and supply volumes will be reconciled through meter readings at each individual property. Locations of these bulk metering points are as shown in the following schematic diagram:

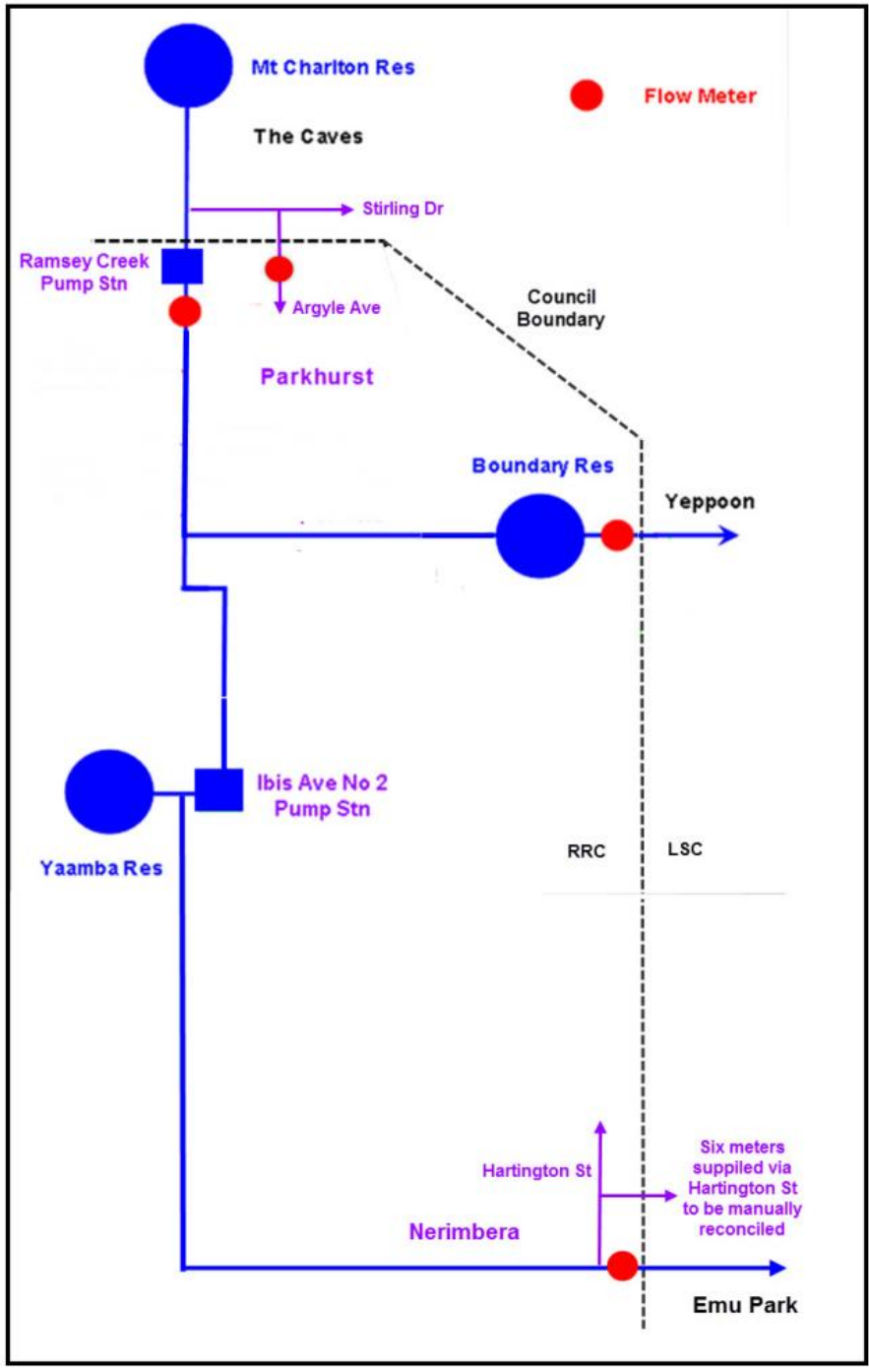

Figure 1 Bulk Meter Installations

- **“Good Operating Practice”**

Both parties acknowledge, understand and agree that their internal processes will need to be reviewed / developed in line with agreed practices, particularly when there is a potential for risk to infrastructure and/or supply to residents within the neighbouring entity, to ensure the following;

- a) Sufficient, adequately experienced and trained personnel are available at all times to operate and maintain the water supply network properly and efficiently;
- b) Reasonable preventative maintenance procedures are in place, and that both routine and non-routine maintenance activities are performed by qualified, trained personnel using appropriate equipment, tools and procedures;
- c) Sufficient notification is given in relation to planned maintenance activities that have the potential to impact on infrastructure and/or supply to residents within the neighbouring entity;
- d) Timely notification is provided to inform the other entity of any unplanned or reactive maintenance activities or events that have the potential to impact on infrastructure or the delivery of services to residents within the neighbouring entity;
- e) Appropriate monitoring and testing is done to ensure equipment is functioning as designed, as per each councils preventative maintenance program;

- **Responding to Network Operational Instructions**

- ***Purpose and Scope***

The purpose of this section is to define the requirements of FRW in regard to demand forecasting from LSC. This demand forecasting is essential to FRW's operation of the GWTP and associated infrastructure to ensure that demand in all water supply schemes supplied by the GWTP is met.

- ***Responsibilities and Accountabilities***

- ***Monthly Forecast***

FRW requires that LSC provides forecasts detailing the estimated quantity of water (ML) required to be transferred beyond each of the Bulk Transfer/Metering Points (as detailed in Section 7) during the coming month. This monthly forecast is to be received

a minimum of 14 days before the end of the month prior. Amendments to this forecast will be submitted to the FRW Coordinator Treatment and Supply for consideration if unforeseen circumstances arise that lead to a change in forecast demand.

- *Weekly Forecast*

FRW requires that LSC provides weekly forecasts detailing the estimated quantity of water (ML) to be transferred beyond each of the Bulk Transfer/Metering Points (as detailed in Section 7) for each day of the coming week. This weekly forecast of daily estimates will be received a minimum of 4 days before the end of the week prior.

- *Unplanned Interruptions*

FRW requires that LSC immediately advise of any unplanned interruptions that have the potential to impact on either the quantity or quality of the water supply to residents within the RRC or the operation of any infrastructure controlled by FRW.

LSC will require that FRW immediately advise of any unplanned interruptions that have the potential to impact on either the quantity or quality of the water supply to residents within the LSC, or the operation of any infrastructure controlled by LSC.

- *Obligations of Each Party*

Each party is obligated to ensure that water supply infrastructure is operated in an appropriate manner required to meet the daily and monthly supply volumes as per the above forecasts. It is acknowledged that the actual daily and monthly volumes of drinking water used will vary slightly due to normal fluctuations in demand patterns.

- *Drought Management*

FRW and LSC will each operate their respective water supply schemes in accordance with that Council's Drought Management Plan. It is therefore the responsibility of each Council to manage water demand accordingly. The implementation of water restrictions will be at the discretion of each Council in accordance with the Drought Management Plan. Water restrictions implemented by either Council should, where practicable, not impact on the ability of the other Council to meet the expected level of service to meet demand in accordance with the Drought Management Plan, and to satisfy the bulk water supply arrangements prescribed by this agreement.

- **Water Quality and Disinfection Management**

- ***Purpose and Scope***

Both FRW and LSC will conduct their own drinking water quality monitoring and reporting program in accordance with approved Drinking Water Quality Management Plans and the Australian Drinking Water Guidelines (ADWG). The purpose of this section is to document the process for advising operators of water quality issues/concerns that have the potential to impact the quality of drinking water supplied by either party to enable timely reaction to potential risks to water quality.

- ***Responsibilities and Accountabilities***

- *Monthly Water Quality Reporting*

FRW will provide to LSC on a monthly basis the results of standard physical and chemical tests on raw water and drinking water sampled at the GWTP. These results will be provided to the relevant water quality officer in LSC within 5 working days of receipt of the results as per the DWQMP.

- *Notification of Water Quality Non-Compliances*

Each party is to notify the other of any water quality non-compliance against either health or aesthetic guidelines listed in the Australian Drinking Water Guidelines that has the potential to impact the quality of drinking water in either the RRC or LSC drinking water supply schemes. This notification should be provided within 5 hours of the detection of a non-compliance and will be provided to the relevant operations officers responsible for managing drinking water quality in each Council. The party receiving water may choose to reduce or halt supply without compromising minimum daily take provisions stated elsewhere in this agreement.

Parameter	Health or Aesthetic Notification Limit	Duration
Physical, chemical or biological parameter	As per ADWG	Start date and time and end time or ongoing

- *Notification of Cessation or Rectification of Water Quality Non-Compliance*

Each party is to notify the other of the cessation of a period of water quality non-compliance and any action taken to rectify the non-compliance. This notification is to be provided to the relevant operations officers responsible for managing drinking water quality in each Council as soon as reasonably possible of the cessation of the non-compliance.

- *Disinfection Management*

All disinfection including the operation of reservoir re-chlorination facilities will be performed in accordance with the approved Drinking Water Quality Management Plan currently in use by FRW and to be utilised by LSC until their own plan is developed and approved. LSC will be required to develop its own Drinking Water Quality Management Plan, which will set out the disinfection management requirements for their customers. FRW will endeavour to comply with these new requirements, where reasonable.

- **Asset Management**

- *Purpose and Scope*

The purpose of this section is to define asset management coordination activities between FRW and the LSC.

- *Responsibilities and Accountabilities*

FRW and LSC are to be responsible for:

- a) Maintaining separate asset registers which contain detailed information about the location of equipment installed by both region and facility. These are to be controlled documents, stored within the respective entities environment, and shared when required;
- b) Producing and implementing an asset management regime to achieve key goals of network availability, reliability and production requirements; and
- c) Ensuring that any planned maintenance and or changes to their respective networks do not adversely affect other parties.

- **Security and site access**

- *Purpose and scope*

The purpose of this section is to define the security and site access arrangements which will exist between FRW and LSC.

- *Responsibilities and Accountabilities*

Both FRW and LSC are responsible for the following where it pertains to assets owned, operated and maintained by each entity:

- Physical security of assets and control of those assets;

- Implementation of relevant WH&S, OH&S and environmental response procedures for sites under their control; and
 - Coordinating in advance their site access requirements to sites owned by the other party.
- *Access requirements*

Where appropriate, both FRW and LSC will be responsible for forecasting at least 14 days in advance any specific requirement to access the other party's sites for planned maintenance activities. This access request must at a minimum include:

- Location of the site being accessed;
- Duration, start date estimated times of access;
- Purpose;
- Any potential for disruption to normal operations and continuity of services; and
- Details of personnel involved, including contact details for the relevant supervisor(s).

This request will be reviewed by the relevant LSC and FRW operations manager or delegate who is acting on behalf of the owner of the asset, who will also clarify any access constraints / conflicts to ensure an approved access program, is in place 7 days prior to the site visit.

Once this request is agreed upon, the relevant delegate will ensure the sites (and personnel visiting them) are issued with an approval to access the site to complete the approved works activities.

Any changes to the approved works activities or site access requirements are to be directed through the appropriate site manager/supervisor.

Access to the site will be arranged by the visiting entity, who will contact the operations control room in relation to temporarily obtaining access to the site. Sign in/sign out, escorting and induction requirements will be confirmed during this contact. Control of visitors with regard to following policies and procedures is the responsibility of each operating entity. Site entrance will indicate acceptance of the operator's requirements.

Access to LSC infrastructure located at any sites owned by FRW is to be coordinated through the FRW Operations Control Room located at GWTP. Equally, any site access to LSC infrastructure can be coordinate through the Supervisor of Treatment located at the Cordingley Street Depot.

- **Risk and Incident Management**

- ***Purpose and Scope***

This section aims to define risk and incident management coordination activities between FRW and LSC.

- ***Responsibilities & Accountabilities***

FRW and LSC are responsible for developing their own risk and incident management plans and procedures. In each Council drinking water incidents will be responded to in accordance with the process defined in the approved Drinking Water Quality Management Plan (DWQMP) used by each Council.

- **Provision of SCADA Data**

- ***Purpose and Scope***

The purpose of this section is to define any data sharing arrangements which may be required between FRW and LSC. It is assumed that this provision of SCADA data does not include any other established regular reporting or information transfer related to quantity or quality of water supplied to the each party. It is also assumed that any requests made on a reactive basis to a water quality or other specific water supply incident will be dealt with on a different basis. In this instance direct contact should be made with the FRW Operations Control Room at the GWTP as per the communications schedule.

- ***Responsibilities and Accountabilities***

It is assumed that each operator will only possess the ability to monitor via telemetry/SCADA those assets owned by each organisation and that there will be no shared monitoring via common telemetry/SCADA. However, output signal from field sensor or on-line instrument might be shared

In the event of a site requiring data to be sent to both FRW and LSC, it is likely that each party will install their own hardware on site where feasible. It is therefore expected that some regular exchanges of data will be required in order for both entities to have the best understanding of the operation of co-dependent assets associated with the supply of water and sewerage services.

- ***Nature of SCADA Data Request***

The SCADA data request and shared algorithms will be developed, agreed, implemented, and maintained between both parties covering the following:

- Shared SCADA site and location information (i.e. GPS coordinates);
- SCADA equipment types;
- SCADA data request requirements;
- SCADA data transmission mechanism;
- Agreed operating levels, water quality, reservoir levels, polling intervals etc; and
- Alarming set points and mechanism (i.e. SMS).

- ***Submitting a Request for SCADA Data***

Requests for SCADA data must be made in writing to the FRW Coordinator Treatment and Supply or relevant officer in LSC responsible for water and sewerage operations. This request must state clearly the asset/s, parameter/s and time period/s for which SCADA data is requested. Additionally LSC may seek to obtain historical data for LSC owned assets during the first 7 years of maintaining their network, until they build up an equivalent level of data within their own network.

- ***Provision of SCADA Data***

Requests for SCADA data must be responded to within 10 working days through the provision of SCADA data in Excel spreadsheet form. As indicated above, where the provision of SCADA data is being made to respond to or rectify a water quality or water supply incident, direct contact should be made with the FRW Operations Control Room by phoning the number listed in the communications schedule or the LSC Water and Sewerage Dispatch by phoning the number listed in the communications schedule.

- ***Provision of SCADA Network Transmission Sites***

It is assumed that LSC will require access to and use of FRW SCADA network transmission and hosting sites at Mt Archer. This involves providing hosting services for LSC's telemetry and microwave communications equipment including radio towers, uninterrupted power, racking space, security, climate protection and communication hut. However, it is envisaged that the management and maintenance of the SCADA network devices is the sole responsibility of LSC (i.e. microwave dishes, telemetry antennas, Radtel, Miri and Trios telemetry devices, RTUs and repeaters).

- **Operational Controls**

- ***Purpose and Scope***

The purpose of this section is to define and document the Operating Controls at appropriate infrastructure interfaces between FRW and LSC.

- ***Responsibilities and Accountabilities***

It is recognised that the clear definition of operational responsibilities and accountabilities at network infrastructure interfaces will assist both FRW and LSC in the efficient management of their infrastructure.

Special operating arrangements are currently in place to ensure the water supply network achieves continuity of supply to customers including major customers (e.g. abattoirs). Accordingly, both parties will ensure that the other party is notified of any intended change to the operation of the water supply network, including the addition of new major customers that can potentially interrupt the current continuity of service.

- ***Site specific requirements***

- ***Boundary Reservoir***

The Boundary Reservoir and the Ibis Avenue WPS which pumps water to this reservoir will be owned, operated and maintained by FRW to maintain a reservoir level between 70% and 95% storage level unless otherwise advised due to an operational change associated with a planned or reactive event or in order to respond to a period of increased demand. Re-chlorination at this reservoir will be performed as outlined in the current approved Drinking Water Quality Management Plan.

- ***Ramsay Creek WPS and Mt Charlton Reservoir***

The Ramsay Creek WPS and Mt Charlton Reservoir will be owned, operated and maintained by FRW and LSC respectively with operation to continue according to the current SCADA-based mode of operation of Ramsay Creek WPS to fill the Mt Charlton Reservoir. The Ramsay Creek WPS will be owned, operated and maintained by FRW to achieve a reservoir level in the LSC-owned Mt Charlton Reservoir of between 70 and 95% unless otherwise advised due to a planned or reactive event or an operational change made to meet increased demand.

- *Nerimbera Water Supply Scheme*

The Nerimbera Water Supply Scheme will be operated as it is currently operated to ensure continuity of supply to the Nerimbera area via a gravity or pumped system to meet demand. Any change to the operation of this infrastructure will be subject to any changes in the requirements of LSC.

- **Stakeholder and Media Management**

- *Purpose and Scope*

The purpose of this section is to define the Stakeholder Management and Media communications between FRW and LSC, enabling consistent communication if liaising with the media is required.

- *Responsibilities and Accountabilities*

Should an event occur has the potential to impact customers for both areas, neither party should make comment to the media or public without first agreeing on a strategy for managing the communications for the incident. In the instance where there is an incident that affects both areas, the respective council will be notified. In any case, this should be covered off in the Customer Service Standards. For incidences, protocols for dealing with the media and for communication between councils, respective Customer Services Standards should be followed.

Where media issues arise, it is the responsibility of the council that is affected to alert their customers. This is for pre-emptive purposes as well as for issues that the media is investigating or already reporting on.

At no time should one operator make comment/statement to the media on behalf of the other, unless key messages relevant to the issue are agreed to in advance.

- *Unplanned incident or event*

In accordance to the RRC Customer Service Standards, the nominated representatives shall be notified where an event or incident affecting either parties or both. Depending on the severity of the event – an unresolved incident shall be escalated to the Director of Infrastructure Services – LSC and Manager of Fitzroy Water Services.

- **Definition and Glossary of Terms**

ADWG – Australian Drinking Water Guidelines

DWQMP – Drinking Water Quality Management Plan

WTP – Water Treatment Plant

WPS – Water Pump Station

WH&S – Workplace Health and Safety

FRW – Fitzroy River Water. In this schedule, FRW refers to the specific operating unit of Rockhampton Regional Council responsible for the supply and delivery of water and sewerage services to both RRC and LSC.

RRC – Rockhampton Regional Council. In this schedule, RRC refers to the legal parent entity responsible for delivering all council services to its constituents.

LSC – Livingstone Shire Council. In this Schedule, LSC includes both the legal entity and the operating unit responsible for the supply and delivery of water and sewerage services to its customer.

GWTP – Glenmore Water Treatment Plant

SCADA – Supervisory Control and Data Acquisition

GPS – Global Positioning System

SMS – Short Message Service

Incident – Unplanned event that interrupts the continuity of service

Operator – The entity, business unit or organisation accountable for managing and delivering water and sewerage services

- **Review Date**

This Schedule is to be reviewed regularly through an Annual Process to determine currency and appropriateness.

The standard distribution of this document is:

Copy Number	Organisation	Title	Name
1	FRW	General Manager Regional Services	Bob Holmes
2	FRW	Manager - Fitzroy River Water	Nimish Chand
3	LSC	Director Infrastructure Services	Dan Toon
4	FRW	Coordinator Treatment and	Jason Plumb



Drinking Water Quality Management Plan



		Supply	
5	LSC	Manager – Waste and Water Operations	Sean Fallis

- **Addendum A – Key Stakeholders List**

- ***Fitzroy River Water***

Name	Job Title	Business Phone	Mobile Phone	E-mail Address
Bob Holmes	General Manager Regional Services	07 4936 8720		Robert.holmes@rrc.qld.gov.au
Nimish Chand	Manager - Fitzroy River Water	07 4936 8720		Nimish.chand@rrc.qld.gov.au
Jason Plumb	Coordinator Treatment and Supply	07 4936 8750	0419 765 046	jason.plumb@rrc.qld.gov.au

- ***Livingstone Shire Council***

Name	Job Title	Business Phone	Mobile Phone	E-mail Address
Dan Toon	Director Infrastructure Services	07 4939 9810	0419687931	Dan.Toon@livingstone.qld.gov.au
Sean Fallis	Manager – Waste and Water Operations	07 4939 9809	0417 647 262	Sean.Fallis@livingstone.qld.gov.au
John Massingham	Process Systems Technician		0457 812 119	John.Massingham@livingstone.qld.gov.au

- **Addendum B – Key Sites List**

- ***Fitzroy River Water***

Name	Hours of Operation	Daytime Phone	After hours Phone
Fitzroy River Water Control Room	24/7	4936 8719 or 4936 8724	4936 8719 or 4936 8724

- ***Livingstone Shire Council***

Name	Hours of Operation	Daytime Phone	After hours Phone
LSC Water and Sewerage Dispatch	7:30am – 4:30pm	49313829	Not applicable



Drinking Water Quality Management Plan

